



The CENTRE for EDUCATION
in MATHEMATICS and COMPUTING
cemc.uwaterloo.ca

Hypatia Contest

(Grade 11)

Thursday, April 18, 2013

(in North America and South America)

Friday, April 19, 2013

(outside of North America and South America)

UNIVERSITY OF
WATERLOO

**WATERLOO
MATHEMATICS**

Deloitte.

©2013 University of Waterloo

Do not open this booklet until instructed to do so.

Time: 75 minutes

Calculators are permitted

Number of questions: 4

Each question is worth 10 marks

Parts of each question can be of two types:

1. **SHORT ANSWER** parts indicated by 

- worth 2 or 3 marks each
- full marks given for a correct answer which is placed in the box
- **part marks awarded only if relevant work** is shown in the space provided

2. **FULL SOLUTION** parts indicated by 



- worth the remainder of the 10 marks for the question
- **must be written in the appropriate location** in the answer booklet
- marks awarded for completeness, clarity, and style of presentation
- a correct solution poorly presented will not earn full marks

WRITE ALL ANSWERS IN THE ANSWER BOOKLET PROVIDED.

- Extra paper for your finished solutions supplied by your supervising teacher must be inserted into your answer booklet. Write your name, school name, and question number on any inserted pages.
- Express calculations and answers as exact numbers such as $\pi + 1$ and $\sqrt{2}$, etc., rather than as 4.14... or 1.41..., except where otherwise indicated.

Do not discuss the problems or solutions from this contest online for the next 48 hours.

The name, grade, school and location of some top-scoring students will be published on our Web site, <http://www.cemc.uwaterloo.ca>. In addition, the name, grade, school and location, and score of some top-scoring students may be shared with other mathematical organizations for other recognition opportunities.

- TIPS:
1. Please read the instructions on the front cover of this booklet.
 2. Write all answers in the answer booklet provided.
 3. For questions marked , place your answer in the appropriate box in the answer booklet and **show your work**.
 4. For questions marked , provide a well-organized solution in the answer booklet. Use mathematical statements and words to explain all of the steps of your solution. Work out some details in rough on a separate piece of paper before writing your finished solution.
 5. Diagrams are *not* drawn to scale. They are intended as aids only.

1. At the JK Mall grand opening, some lucky shoppers are able to participate in a money giveaway. A large box has been filled with many \$5, \$10, \$20, and \$50 bills. The lucky shopper reaches into the box and is allowed to pull out one handful of bills.

 (a) Rad pulls out at least two bills of each type and his total sum of money is \$175. What is the total number of bills that Rad pulled out?

 (b) Sandy pulls out exactly five bills and notices that she has at least one bill of each type. What are the possible sums of money that Sandy could have?

 (c) Lino pulls out six or fewer bills and his total sum of money is \$160. There are exactly four possibilities for the number of each type of bill that Lino could have. Determine these four possibilities.

2. A parabola has equation $y = (x - 3)^2 + 1$.

 (a) What are the coordinates of the vertex of the parabola?

 (b) A new parabola is created by translating the original parabola 3 units to the left and 3 units up. What is the equation of the translated parabola?

 (c) Determine the coordinates of the point of intersection of these two parabolas.

 (d) The parabola with equation $y = ax^2 + 4$, $a < 0$, touches the parabola with equation $y = (x - 3)^2 + 1$ at exactly one point. Determine the value of a .

3. A sequence of m P's and n Q's with $m > n$ is called *non-predictive* if there is some point in the sequence where the number of Q's counted from the left is greater than or equal to the number of P's counted from the left.

For example, if $m = 5$ and $n = 2$ the sequence PPQQPPP is non-predictive because in counting the first four letters from the left, the number of Q's is equal to the number of P's. Also, the sequence QPPPQPP is non-predictive because in counting the first letter from the left, the number of Q's is greater than the number of P's.



- (a) If $m = 7$ and $n = 2$, determine the number of non-predictive sequences that begin with P.



- (b) Suppose that $n = 2$. Show that for every $m > 2$, the number of non-predictive sequences that begin with P is equal to the number of non-predictive sequences that begin with Q.



- (c) Determine the number of non-predictive sequences with $m = 10$ and $n = 3$.

- 4.



- (a) Twenty cubes, each with edge length 1 cm, are placed together in 4 rows of 5. What is the surface area of this rectangular prism?

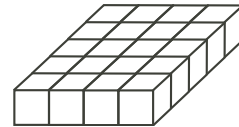

- (b) A number of cubes, each with edge length 1 cm, are arranged to form a rectangular prism having height 1 cm and a surface area of 180 cm^2 . Determine the number of cubes in the rectangular prism.



- (c) A number of cubes, each with edge length 1 cm, are arranged to form a rectangular prism having length l cm, width w cm, and thickness 1 cm. A frame is formed by removing a rectangular prism with thickness 1 cm located k cm from each of the sides of the original rectangular prism, as shown. Each of l , w and k is a positive integer. If the frame has surface area 532 cm^2 , determine all possible values for l and w such that $l \geq w$.

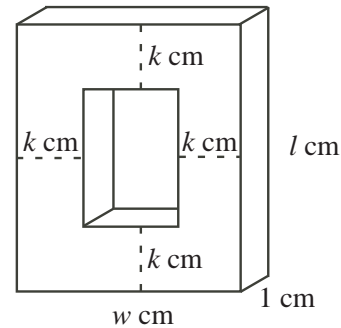



The CENTRE for EDUCATION
in MATHEMATICS and COMPUTING
cemc.uwaterloo.ca

For students...

Thank you for writing the 2013 Hypatia Contest!
In 2012, more than 13 000 students from around the world registered to write the Fryer, Galois and Hypatia Contests.

Encourage your teacher to register you for the Canadian Intermediate Mathematics Contest or the Canadian Senior Mathematics Contest, which will be written in November 2013.

Visit our website to find

- Free copies of past contests
- Workshops to help you prepare for future contests
- Information about our publications for mathematics enrichment and contest preparation

For teachers...

Visit our website to

- Obtain information about our 2013/2014 contests
- Learn about our face-to-face workshops and our resources
- Find your school contest results
- Subscribe to the Problem of the Week
- Read about our Master of Mathematics for Teachers program



The CENTRE for EDUCATION
in MATHEMATICS and COMPUTING

www.cemc.uwaterloo.ca

Hypatia Contest

(Grade 11)

Thursday, April 12, 2012

(in North America and South America)

Friday, April 13, 2012

(outside of North America and South America)

UNIVERSITY OF
WATERLOO

**WATERLOO
MATHEMATICS**

THE
Great-West Life
ASSURANCE COMPANY



 **Canada Life**

STRONGER COMMUNITIES TOGETHER™

Canadian
Institute of
Actuaries  Institut
canadien
des actuaires

Deloitte.

©2012 University of Waterloo

Do not open this booklet until instructed to do so.

Time: 75 minutes

Number of questions: 4

Calculators are permitted

Each question is worth 10 marks

Parts of each question can be of two types:

1. **SHORT ANSWER** parts indicated by



- worth 2 or 3 marks each
- full marks given for a correct answer which is placed in the box
- **part marks awarded only if relevant work** is shown in the space provided

2. **FULL SOLUTION** parts indicated by



- worth the remainder of the 10 marks for the question
- **must be written in the appropriate location** in the answer booklet
- marks awarded for completeness, clarity, and style of presentation
- a correct solution poorly presented will not earn full marks



WRITE ALL ANSWERS IN THE ANSWER BOOKLET PROVIDED.

- Extra paper for your finished solutions supplied by your supervising teacher must be inserted into your answer booklet. Write your name, school name, and question number on any inserted pages.
- Express calculations and answers as exact numbers such as $\pi + 1$ and $\sqrt{2}$, etc., rather than as 4.14... or 1.41..., except where otherwise indicated.

Do not discuss the problems or solutions from this contest online for the next 48 hours.





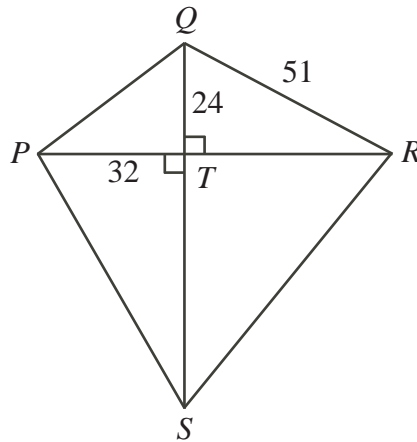

The name, grade, school and location of some top-scoring students will be published in the FGHS Results on our Web site, <http://www.cemc.uwaterloo.ca>.

TIPS:

1. Please read the instructions on the front cover of this booklet.
2. Write all answers in the answer booklet provided.
3. For questions marked , place your answer in the appropriate box in the answer booklet and **show your work**.
4. For questions marked , provide a well-organized solution in the answer booklet. Use mathematical statements and words to explain all of the steps of your solution. Work out some details in rough on a separate piece of paper before writing your finished solution.
5. Diagrams are *not* drawn to scale. They are intended as aids only.

1. Quadrilateral $PQRS$ is constructed with $QR = 51$, as shown. The diagonals of $PQRS$ intersect at 90° at point T , such that $PT = 32$ and $QT = 24$.



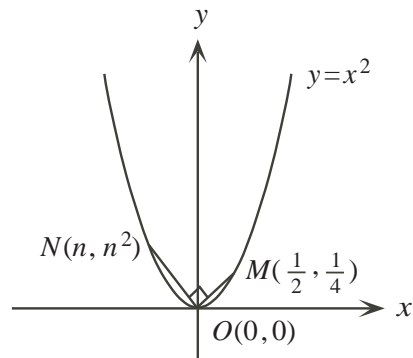

-  (a) Calculate the length of PQ .
 -  (b) Calculate the area of $\triangle PQR$.
 -  (c) If $QS : PR = 12 : 11$, determine the perimeter of quadrilateral $PQRS$.
- 2.
-  (a) Determine the value of $(a + b)^2$, given that $a^2 + b^2 = 24$ and $ab = 6$.
 -  (b) If $(x + y)^2 = 13$ and $x^2 + y^2 = 7$, determine the value of xy .
 -  (c) If $j + k = 6$ and $j^2 + k^2 = 52$, determine the value of jk .
 -  (d) If $m^2 + n^2 = 12$ and $m^4 + n^4 = 136$, determine all possible values of mn .

3.  (a) Points $M(\frac{1}{2}, \frac{1}{4})$ and $N(n, n^2)$ lie on the parabola with equation $y = x^2$, as shown. Determine the value of n such that $\angle MON = 90^\circ$.



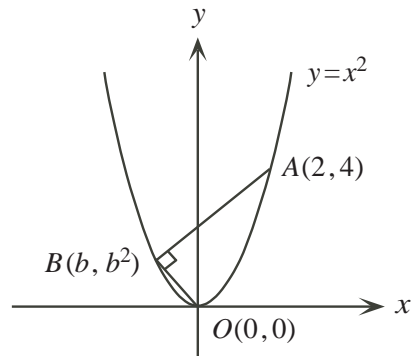

-  (b) Points $A(2, 4)$ and $B(b, b^2)$ are the endpoints of a chord of the parabola with equation $y = x^2$, as shown. Determine the value of b so that $\angle ABO = 90^\circ$.

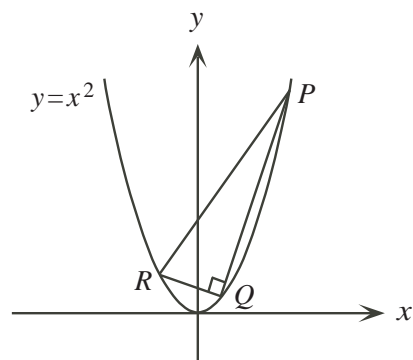

-  (c) Right-angled triangle PQR is inscribed in the parabola with equation $y = x^2$, as shown. Points P, Q and R have coordinates $(p, p^2), (q, q^2)$ and (r, r^2) , respectively. If p, q and r are integers, show that $2q + p + r = 0$.



4. The positive divisors of 21 are 1, 3, 7 and 21. Let $S(n)$ be the sum of the positive divisors of the positive integer n . For example, $S(21) = 1 + 3 + 7 + 21 = 32$.

-  (a) If p is an odd prime integer, find the value of p such that $S(2p^2) = 2613$.
-  (b) The consecutive integers 14 and 15 have the property that $S(14) = S(15)$. Determine all pairs of consecutive integers m and n such that $m = 2p$ and $n = 9q$ for prime integers $p, q > 3$, and $S(m) = S(n)$.
-  (c) Determine the number of pairs of distinct prime integers p and q , each less than 30, with the property that $S(p^3q)$ is not divisible by 24.



The CENTRE for EDUCATION in MATHEMATICS and COMPUTING

For students...

Thank you for writing the 2012 Hypatia Contest!
In 2011, more than 13 000 students from around the world registered to write the Fryer, Galois and Hypatia Contests.

Encourage your teacher to register you for the Canadian Intermediate Mathematics Contest or the Canadian Senior Mathematics Contest, which will be written in November 2012.

Visit our website to find

- Free copies of past contests
- Workshops to help you prepare for future contests
- Information about our publications for mathematics enrichment and contest preparation

For teachers...

Visit our website to

- Obtain information about our 2012/2013 contests
- Learn about our face-to-face workshops and our resources
- Find your school contest results
- Subscribe to the Problem of the Week
- Read about our Master of Mathematics for Teachers program

www.cemc.uwaterloo.ca

2011 Hypatia Contest (Grade 11)

Wednesday, April 13, 2011

1. In the diagram, D and E are the midpoints of AB and BC respectively.

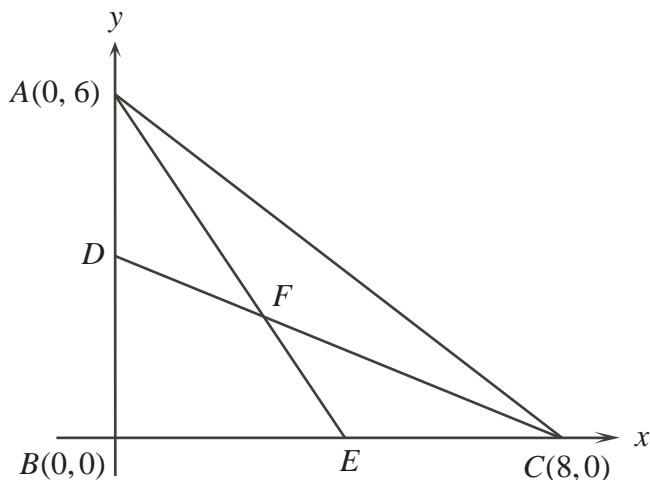

- Determine an equation of the line passing through the points C and D .
 - Determine the coordinates of F , the point of intersection of AE and CD .
 - Determine the area of $\triangle DBC$.
 - Determine the area of quadrilateral $DBEF$.
2. A set S consists of all two-digit numbers such that:
- no number contains a digit of 0 or 9, and
 - no number is a multiple of 11.
- Determine how many numbers in S have a 3 as their tens digit.
 - Determine how many numbers in S have an 8 as their ones digit.
 - Determine how many numbers are in S .
 - Determine the sum of all the numbers in S .
3. Positive integers (x, y, z) form a *Trenti-triple* if $3x = 5y = 2z$.
- Determine the values of y and z in the Trenti-triple $(50, y, z)$.
 - Show that for every Trenti-triple (x, y, z) , y must be divisible by 6.
 - Show that for every Trenti-triple (x, y, z) , the product xyz must be divisible by 900.

4. Let $F(n)$ represent the number of ways that a positive integer n can be written as the sum of positive odd integers. For example,

- $F(5) = 3$ since

$$\begin{aligned} 5 &= 1 + 1 + 1 + 1 + 1 \\ &= 1 + 1 + 3 \\ &= 5 \end{aligned}$$

- $F(6) = 4$ since

$$\begin{aligned} 6 &= 1 + 1 + 1 + 1 + 1 + 1 \\ &= 1 + 1 + 1 + 3 \\ &= 3 + 3 \\ &= 1 + 5 \end{aligned}$$

- Find $F(8)$ and list all the ways that 8 can be written as the sum of positive odd integers.
- Prove that $F(n+1) > F(n)$ for all integers $n > 3$.
- Prove that $F(2n) > 2F(n)$ for all integers $n > 3$.

2010 Hypatia Contest (Grade 11)
Friday, April 9, 2010

1. Piravena must make a trip from A to B , then from B to C , then from C to A . Each of these three parts of the trip is made entirely by bus or entirely by airplane. The cities form a right-angled triangle as shown, with C a distance of 3000 km from A and with B a distance of 3250 km from A . To take a bus, it costs Piravena \$0.15 per kilometre. To take an airplane, it costs her a \$100 booking fee, plus \$0.10 per kilometre.

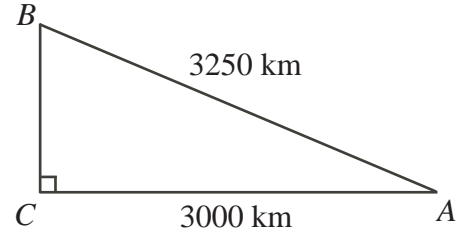

- (a) To begin her trip she flew from A to B . Determine the cost to fly from A to B .
- (b) Determine the distance she travels for her complete trip.
- (c) Piravena chose the least expensive way to travel between cities and her total cost was \$1012.50. Given that she flew from A to B , determine her method of transportation from B to C and her method of transportation from C to A .
2. A function f is such that $f(x) - f(x - 1) = 4x - 9$ and $f(5) = 18$.
- (a) Determine the value of $f(6)$.
- (b) Determine the value of $f(3)$.
- (c) If $f(x) = 2x^2 + px + q$, determine the values of p and q .

3. In the diagram, square $ABCD$ has sides of length 4, and $\triangle ABE$ is equilateral. Line segments BE and AC intersect at P . Point Q is on BC so that PQ is perpendicular to BC and $PQ = x$.

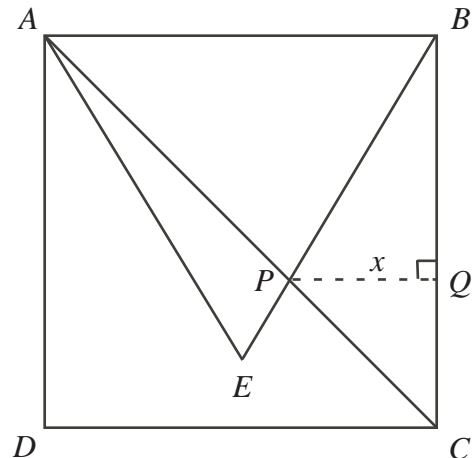

- (a) Determine the measures of the angles of $\triangle BPC$.
- (b) Find an expression for the length of BQ in terms of x .
- (c) Determine the exact value of x .
- (d) Determine the exact area of $\triangle APE$.

-
4. (a) Determine all real values of x satisfying the equation $x^4 - 6x^2 + 8 = 0$.
- (b) Determine the smallest positive integer N for which $x^4 + 2010x^2 + N$ can be factored as $(x^2 + rx + s)(x^2 + tx + u)$ with r, s, t, u integers and $r \neq 0$.
- (c) Prove that $x^4 + Mx^2 + N$ cannot be factored as in (b) for any integers M and N with $N - M = 37$.

2009 Hypatia Contest (Grade 11)
Wednesday, April 8, 2009

1. Emma counts the number of students in her class with each eye and hair colour, and summarizes the results in the following table:

		Hair Colour		
		Brown	Blonde	Red
Eye Colour	Blue	3	2	1
	Green	2	4	2
	Brown	2	3	1

- (a) What percentage of the students have both green eyes and brown hair?
- (b) What percentage of the students have green eyes or brown hair or both?
- (c) Of the students who have green eyes, what percentage also have red hair?
- (d) Determine how many students with red hair must join the class so that the percentage of the students in the class with red hair becomes 36%.
2. An arithmetic sequence is a sequence in which each term after the first is obtained from the previous term by adding a constant d , called the common difference. For example, the sequence 2, 11, 20, 29, 38 is an arithmetic sequence with five terms and a common difference of $d = 9$.
- (a) An arithmetic sequence has three terms. The three terms add to 180. Determine the middle term of this sequence.
- (b) An arithmetic sequence has five terms. The five terms add to 180. Show that at least one of the five terms equals 36.
- (c) An arithmetic sequence has six terms. The six terms in the sequence add to 180. Determine the sum of the first and sixth terms of the sequence.
3. Triangle ABC has vertices $A(0, 8)$, $B(2, 0)$, $C(8, 0)$.
- (a) Determine the equation of the line through B that cuts the area of $\triangle ABC$ in half.
- (b) A vertical line intersects AC at R and BC at S , forming $\triangle RSC$. If the area of $\triangle RSC$ is 12.5, determine the coordinates of point R .
- (c) A horizontal line intersects AB at T and AC at U , forming $\triangle ATU$. If the area of $\triangle ATU$ is 13.5, determine the equation of the horizontal line.

4. (a) A solid right prism $ABCDEF$ has a height of 16, as shown. Also, its bases are equilateral triangles with side length 12. Points X , Y , and Z are the midpoints of edges AC , BC , and DC , respectively. Determine the lengths of XY , YZ and XZ .

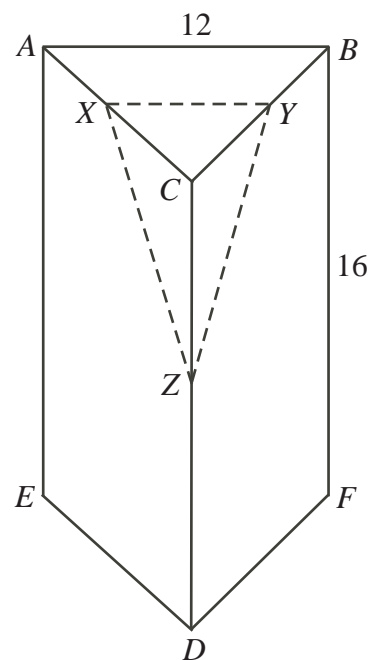

- (b) A part of the prism above is sliced off with a straight cut through points X , Y and Z . Determine the surface area of solid $CXYZ$, the part that was sliced off.

- (c) The prism $ABCDEF$ in part (a) is sliced with a straight cut through points M , N , P , and Q on edges DE , DF , CB , and CA , respectively. If $DM = 4$, $DN = 2$, and $CQ = 8$, determine the volume of the solid $QPCDMN$.

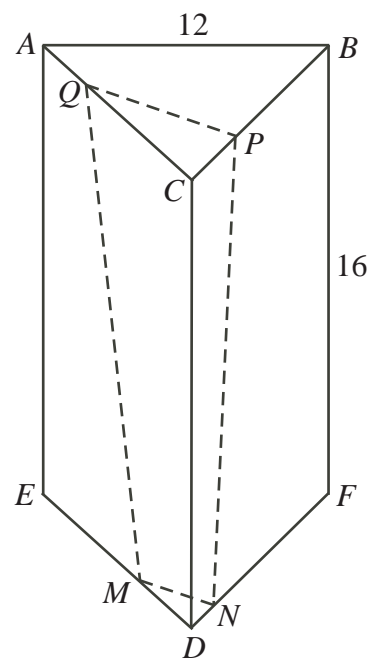

2008 Hypatia Contest (Grade 11)
Wednesday, April 16, 2008

1. For numbers a and b , the notation $a\nabla b$ means $2a + b^2 + ab$.
For example, $1\nabla 2 = 2(1) + 2^2 + (1)(2) = 8$.

- (a) Determine the value of $3\nabla 2$.
- (b) If $x\nabla(-1) = 8$, determine the value of x .
- (c) If $4\nabla y = 20$, determine the two possible values of y .
- (d) If $(w - 2)\nabla w = 14$, determine all possible values of w .

2. (a) Determine the equation of the line through the points $A(7, 8)$ and $B(9, 0)$.
- (b) Determine the coordinates of P , the point of intersection of the line $y = 2x - 10$ and the line through A and B .
- (c) Is P closer to A or to B ? Explain how you obtained your answer.

3. In the diagram, $ABCD$ is a trapezoid with AD parallel to BC and BC perpendicular to AB . Also, $AD = 6$, $AB = 20$, and $BC = 30$.

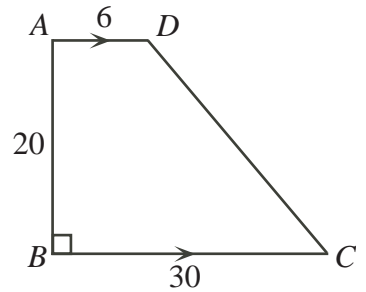

- (a) Determine the area of trapezoid $ABCD$.
 - (b) There is a point K on AB such that the area of $\triangle KBC$ equals the area of quadrilateral $KADC$. Determine the length of BK .
 - (c) There is a point M on DC such that the area of $\triangle MBC$ equals the area of quadrilateral $MBAD$. Determine the length of MC .
4. The *peizi-sum* of a sequence $a_1, a_2, a_3, \dots, a_n$ is formed by adding the products of all of the pairs of distinct terms in the sequence. For example, the peizi-sum of the sequence a_1, a_2, a_3, a_4 is $a_1a_2 + a_1a_3 + a_1a_4 + a_2a_3 + a_2a_4 + a_3a_4$.
- (a) The peizi-sum of the sequence $2, 3, x, 2x$ is -7 . Determine the possible values of x .
 - (b) A sequence has 100 terms. Of these terms, m are equal to 1 and n are equal to -1 . The rest of the terms are equal to 2. Determine, in terms of m and n , the number of pairs of distinct terms that have a product of 1.
 - (c) A sequence has 100 terms, with each term equal to either 2 or -1 . Determine, with justification, the minimum possible peizi-sum of the sequence.

2007 Hypatia Contest (Grade 11)
Wednesday, April 18, 2007

1. The diagram shows four cities A , B , C , and D , with the distances between them in kilometres.

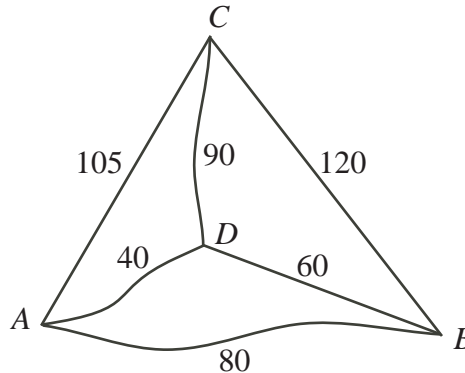

- (a) Penny must travel from A through each of the other cities exactly once and then back to A . An example of her route might be $A \rightarrow B \rightarrow D \rightarrow C \rightarrow A$. List all routes that Penny could travel.
- (b) Identify one route of the shortest possible length and one of the longest possible length. Explain how you obtained your answer.
- (c) Just before leaving A , Penny learns that
- she must visit a fifth city E ,
 - E is connected directly to each of A , B , C , and D , and
 - E must be the third city she visits.

Therefore, the trip would be $A \rightarrow _ \rightarrow _ \rightarrow E \rightarrow _ \rightarrow A$.

How many different routes are now possible? Explain how you obtained your answer.

- (d) The trip $A \rightarrow D \rightarrow C \rightarrow E \rightarrow B \rightarrow A$ is 600 km long.
 The trip $A \rightarrow C \rightarrow D \rightarrow E \rightarrow B \rightarrow A$ is 700 km long.
 The distance from D to E is 225 km.
 What is the distance from C to E ? Explain how you obtained your answer.

2. Olayuk has four pails labelled P , Q , R , and S , each containing some marbles. A “legal move” is to take one marble from each of three of the pails and put the marbles into the fourth pail.
- (a) Initially, the pails contain 9, 9, 1, and 5 marbles. Describe a sequence of legal moves that results in 6 marbles in each pail.
- (b) Suppose that the pails initially contain 31, 27, 27, and 7 marbles. After a number of legal moves, each pail contains the same number of marbles.
- i. Describe a sequence of legal moves to obtain the same number of marbles in each pail.
 - ii. Explain why at least 8 legal moves are needed to obtain the same number of marbles in each pail.
- (c) Beginning again, the pails contain 10, 8, 11, and 7 marbles. Explain why there is no sequence of legal moves that results in an equal number of marbles in each pail.

3. Consider the quadratic function $f(x) = x^2 - 4x - 21$.
- Determine all values of x for which $f(x) = 0$ (that is, $x^2 - 4x - 21 = 0$).
 - If s and t are different real numbers such that $s^2 - 4s - 21 = t^2 - 4t - 21$ (that is, $f(s) = f(t)$), determine the possible values of $s + t$. Explain how you obtained your answer.
 - If a and b are different positive integers such that $(a^2 - 4a - 21) - (b^2 - 4b - 21) = 4$, determine all possible values of a and b . Explain how you obtained your answer.
4. In the diagram, four circles of radius 1 with centres P , Q , R , and S are tangent to one another and to the sides of $\triangle ABC$, as shown.

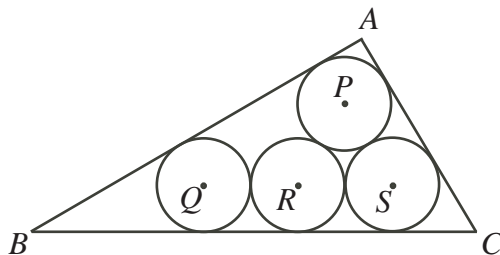

- Determine the size of each of the angles of $\triangle PQS$. Explain how you obtained your answer.
- Determine the length of each side of $\triangle ABC$. Explain how you obtained your answer.
- The radius of the circle with centre R is decreased so that
 - the circle with centre R remains tangent to BC ,
 - the circle with centre R remains tangent to the other three circles, and
 - the circle with centre P becomes tangent to the other three circles.

This changes the size and shape of $\triangle ABC$. Determine r , the new radius of the circle with centre R .

2006 Hypatia Contest (Grade 11)
Thursday, April 20, 2006

1. The odd positive integers are arranged in rows in the triangular pattern, as shown.

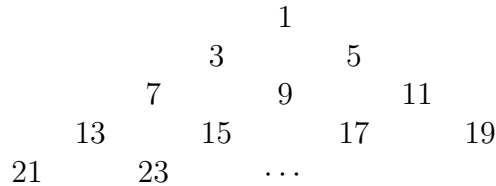

- (a) What is the 25th odd positive integer? In which row of the pattern will this integer appear?
- (b) What is the 19th integer that appears in the 21st row? Explain how you got your answer.
- (c) Determine the row and the position in that row where the number 1001 occurs. Explain how you got your answer.
2. In the diagram, $\triangle ABE$, $\triangle BCE$ and $\triangle CDE$ are right-angled, with $\angle AEB = \angle BEC = \angle CED = 60^\circ$, and $AE = 24$.

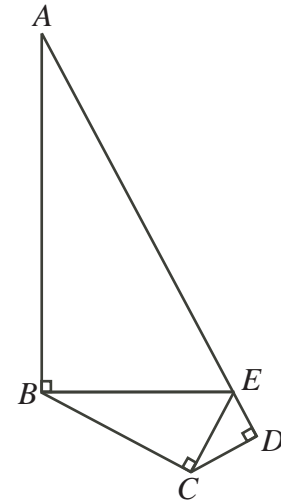

- (a) Determine the length of CE .
- (b) Determine the perimeter of quadrilateral $ABCD$.
- (c) Determine the area of quadrilateral $ABCD$.
3. A line ℓ passes through the points $B(7, -1)$ and $C(-1, 7)$.
- (a) Determine the equation of this line.
- (b) Determine the coordinates of the point P on the line ℓ so that P is equidistant from the points $A(10, -10)$ and $O(0, 0)$ (that is, so that $PA = PO$).
- (c) Determine the coordinates of all points Q on the line ℓ so that $\angle OQA = 90^\circ$.

4. The abundancy index $I(n)$ of a positive integer n is $I(n) = \frac{\sigma(n)}{n}$, where $\sigma(n)$ is the sum of all of the positive divisors of n , including 1 and n itself.

For example, $I(12) = \frac{1 + 2 + 3 + 4 + 6 + 12}{12} = \frac{7}{3}$.

- (a) Prove that $I(p) \leq \frac{3}{2}$ for every prime number p .
- (b) For every odd prime number p and for all positive integers k , prove that $I(p^k) < 2$.
- (c) If p and q are different prime numbers, determine $I(p^2)$, $I(q)$ and $I(p^2q)$, and prove that $I(p^2)I(q) = I(p^2q)$.
- (d) Determine, with justification, the smallest odd positive integer n such that $I(n) > 2$.

2005 Hypatia Contest (Grade 11)
Wednesday, April 20, 2005

1. For numbers a and b , the notation $a \diamond b$ means $a^2 - 4b$. For example, $5 \diamond 3 = 5^2 - 4(3) = 13$.
 - (a) Evaluate $2 \diamond 3$.
 - (b) Find all values of k such that $k \diamond 2 = 2 \diamond k$.
 - (c) The numbers x and y are such that $3 \diamond x = y$ and $2 \diamond y = 8x$. Determine the values of x and y .

2. Gwen and Chris are playing a game. They begin with a pile of toothpicks, and use the following rules:
 - The two players alternate turns
 - On any turn, the player can remove 1, 2, 3, 4, or 5 toothpicks from the pile
 - The same number of toothpicks cannot be removed on two different turns
 - The last person who is able to play wins, regardless of whether there are any toothpicks remaining in the pile

For example, if the game begins with 8 toothpicks, the following moves could occur:

Gwen removes 1 toothpick, leaving 7 in the pile
Chris removes 4 toothpicks, leaving 3 in the pile
Gwen removes 2 toothpicks, leaving 1 in the pile

Gwen is now the winner, since Chris cannot remove 1 toothpick. (Gwen already removed 1 toothpick on one of her turns, and the third rule says that 1 toothpick cannot be removed on another turn.)

- (a) Suppose the game begins with 11 toothpicks. Gwen begins by removing 3 toothpicks. Chris follows and removes 1. Then Gwen removes 4 toothpicks. Explain how Chris can win the game.
- (b) Suppose the game begins with 10 toothpicks. Gwen begins by removing 5 toothpicks. Explain why Gwen can always win, regardless of what Chris removes on his turn.
- (c) Suppose the game begins with 9 toothpicks. Gwen begins by removing 2 toothpicks. Explain how Gwen can always win, regardless of how Chris plays.

3. In the diagram, $\triangle ABC$ is equilateral with side length 4. Points P , Q and R are chosen on sides AB , BC and CA , respectively, such that $AP = BQ = CR = 1$.

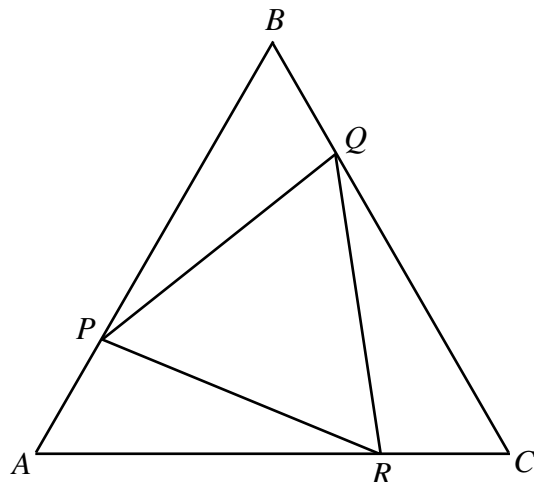

- (a) Determine the exact area of $\triangle ABC$. Explain how you got your answer.
- (b) Determine the exact areas of $\triangle PBQ$ and $\triangle PQR$. Explain how you got your answers.
4. An *arrangement* of a set is an ordering of all of the numbers in the set, in which each number appears exactly once. For example, 312 and 231 are two of the possible arrangements of $\{1, 2, 3\}$.
- (a) Determine the number of triples (a, b, c) where a , b and c are three different numbers chosen from $\{1, 2, 3, 4, 5\}$ with $a < b$ and $b > c$. Explain how you got your answer.
- (b) How many arrangements of $\{1, 2, 3, 4, 5, 6\}$ contain the digits 254 consecutively in that order? Explain how you got your answer.
- (c) A *local peak* in an arrangement occurs where there is a sequence of 3 numbers in the arrangement for which the middle number is greater than both of its neighbours. For example, the arrangement 35241 of $\{1, 2, 3, 4, 5\}$ contains 2 local peaks. Determine, with justification, the average number of local peaks in all 40320 possible arrangements of $\{1, 2, 3, 4, 5, 6, 7, 8\}$.

2004 Hypatia Contest (Grade 11)
Thursday, April 15, 2004

1. (a) Find all values of x which are roots of the equation $x^2 + 5x + 6 = 0$.
- (b) The roots of $x^2 + 5x + 6 = 0$ are each increased by 7. Find a quadratic equation that has these new numbers as roots.
- (c) The roots of $(x - 4)(3x^2 - x - 2) = 0$ are each increased by 1. Find an equation that has these new numbers as roots.
2. Two basketball players, Alan and Bobbie, are standing on level ground near a lamp-post which is 8 m tall. Each of the two players casts a shadow on the ground.

- (a) In the diagram, Alan is standing 2 m from the lamp-post. If Alan is 2 m tall, determine the value of x , the length of his shadow.

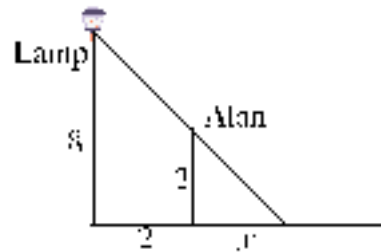

- (b) Bobbie is 1.5 m tall and is standing on the opposite side of the lamp-post from Alan. How far from the lamp-post should she stand so that she casts a shadow of length 3 m?

3. (a) In the diagram, triangle OMN has vertices $O(0,0)$, $M(6,0)$ and $N(0,8)$. Determine the coordinates of point $P(a,b)$ inside the triangle so that the areas of the triangles POM , PON and PMN are all equal.

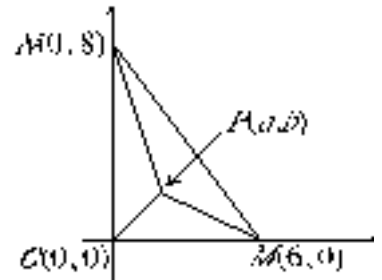

- (b) In the diagram, quadrilateral $OMLK$ has vertices $O(0,0)$, $M(6,0)$, $L(10,t)$, and $K(0,t)$, where $t > 0$. Show that there is no point $Q(c,d)$ inside the quadrilateral so that the areas of the triangles QOM , QML , QLK , and QKO are all equal.

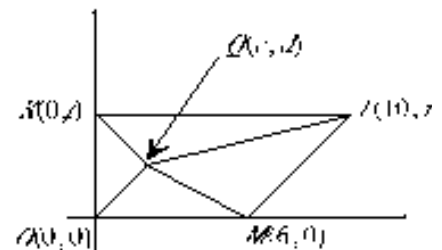

4. (a) 1 green, 1 yellow and 2 red balls are placed in a bag. Two balls of *different* colours are selected at random. These two balls are then removed and replaced with one ball of the *third* colour. (Enough extra balls of each colour are kept to the side for this purpose.) This process continues until there is only one ball left in the bag, or all of the balls are the same colour. What is the colour of the ball or balls that remain at the end?
- (b) 3 green, 4 yellow and 5 red balls are placed in a bag. If a procedure identical to that in part (a) is carried out, what is the colour of the ball or balls that remain at the end?
- (c) 3 green, 4 yellow and 5 red balls are placed in a bag. This time, two balls of different colours are selected at random, removed, and replaced with *two* balls of the third colour. Show that it is impossible for all of the remaining balls to be the same colour, no matter how many times this process is repeated.

2003 Hypatia Contest (Grade 11)

Wednesday, April 16, 2003

1. (a) Quentin has a number of square tiles, each measuring 1 cm by 1 cm. He tries to put these small square tiles together to form a larger square of side length n cm, but finds that he has 92 tiles left over. If he had increased the side length of the larger square to $(n + 2)$ cm, he would have been 100 tiles short of completing the larger square. How many tiles does Quentin have?
- (b) Quentin's friend Rufus arrives with a big pile of identical blocks, each in the shape of a cube. Quentin takes some of the blocks and Rufus takes the rest. Quentin uses his blocks to try to make a large cube with 8 blocks along each edge, but finds that he is 24 blocks short. Rufus, on the other hand, manages to exactly make a large cube using all of his blocks. If they use all of their blocks together, they are able to make a complete cube which has a side length that is 2 blocks longer than Rufus' cube. How many blocks are there in total?
2. Xavier and Yolanda are playing a game starting with some coins arranged in piles. Xavier always goes first, and the two players take turns removing one or more coins from any *one* pile. The player who takes the last coin wins.

- (a) If there are two piles of coins with 3 coins in each pile, show that Yolanda can guarantee that she always wins the game.



- (b) If the game starts with piles of 1, 2 and 3 coins, explain how Yolanda can guarantee that she always wins the game.

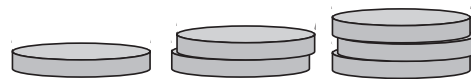

3. In the diagram, the sphere has a diameter of 10 cm. Also, the right circular cone has a height of 10 cm, and its base has a diameter of 10 cm. The sphere and cone sit on a horizontal surface. If a horizontal plane cuts both the sphere and the cone, the cross-sections will both be circles, as shown. Find the height of the horizontal plane that gives circular cross-sections of the sphere and cone of equal area.

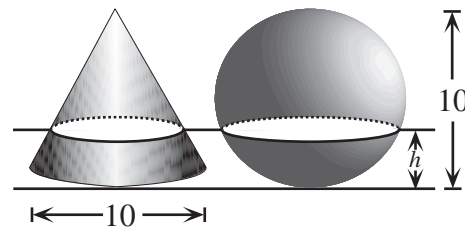

4. Square $ABCD$ has vertices $A(1,4)$, $B(5,4)$, $C(5,8)$, and $D(1,8)$. From a point P outside the square, a vertex of the square is said to be *visible* if it can be connected to P by a straight line that does not pass through the square. Thus, from any point P outside the square, either two or three of the vertices of the square are visible. The *visible area of P* is the area of the one triangle or the sum of the areas of the two triangles formed by joining P to the two or three visible vertices of the square.

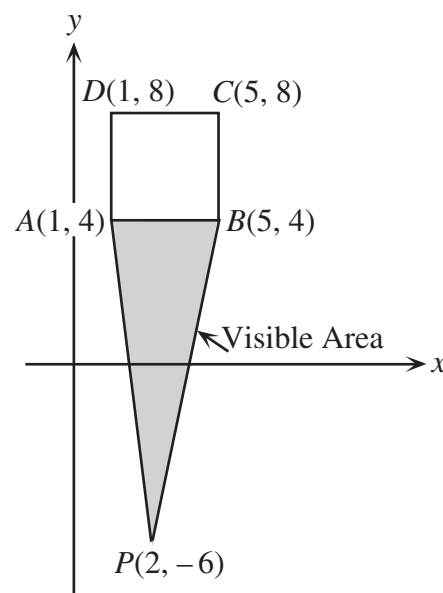

- (a) Show that the *visible area of $P(2,-6)$* is 20 square units.

(b) Show that the visible area of $Q(11, 0)$ is also 20 square units.

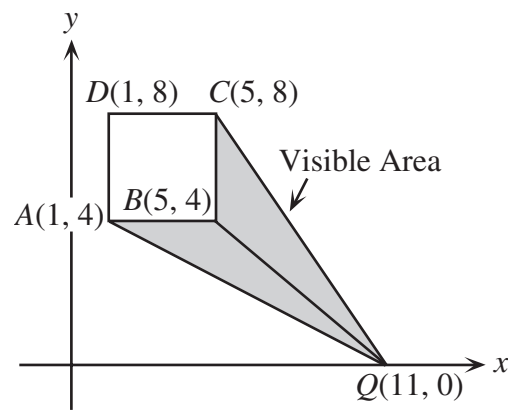

(c) The set of points P for which the visible area equals 20 square units is called the *20/20 set*, and is a polygon. Determine the perimeter of the 20/20 set.

Extensions (Attempt these only when you have completed as much as possible of the four main problems.)

Extension to Problem 1:

As in Question 1(a), Quentin tries to make a large square out of square tiles and has 92 tiles left over. In an attempt to make a second square, he increases the side length of this first square by *an unknown number of tiles* and finds that he is 100 tiles short of completing the square. How many different numbers of tiles is it possible for Quentin to have?

Extension to Problem 2:

If the game starts with piles of 2, 4 and 5 coins, which player wins if both players always make their best possible move? Explain the winning strategy.

Extension to Problem 3:

A sphere of diameter d and a right circular cone with a base of diameter d stand on a horizontal surface. In this case, the height of the cone is equal to the *radius* of the sphere. Show that, for any horizontal plane that cuts both the cone and the sphere, the *sum* of the areas of the circular cross-sections is always the same.

Extension to Problem 4:

From any point P outside a unit cube, 4, 6 or 7 vertices are visible in the same sense as in the case of the square. Connecting point P to each of these vertices gives 1, 2 or 3 square-based pyramids, which make up the *visible volume* of P . The *20/20 set* is the set of all points P for which the visible volume is 20, and is a polyhedron. What is the surface area of this 20/20 set?