

Le CENTRE d'ÉDUCATION en
MATHÉMATIQUES et en INFORMATIQUE

Problème de la semaine

Problèmes et solutions

2021 - 2022

(solutions disponibles en anglais seulement)

Problème C (7^e/8^e année)

Thèmes

(Cliquer sur le nom du thème ci-dessous pour sauter à cette section.)

Sens du nombre (N)

Géométrie et mesure (G)

Algèbre (A)

Gestion des données (D)

Raisonnement informatiques (C)

Les problèmes dans ce livret sont organisés par thème.

Un problème peut apparaître dans plusieurs thèmes.

Sens du nombre (N)





Problème de la semaine

Problème C

Face à face

Les six faces d'un dé régulier sont marquées de 1, 2, 3, 4, 5 et 6 points. Les nombres de points sur deux faces opposées d'un dé régulier forment toujours une somme de 7. Par exemple, la face opposée à la face de 2 points a 5 points.

Dans la figure ci-dessous, quatre dés réguliers sont disposés de manière que, pour n'importe quel couple de dés adjacents, la somme des points cachés sur les faces qui se touchent soit toujours égale à 9. Combien y a-t-il de points sur la face C ?

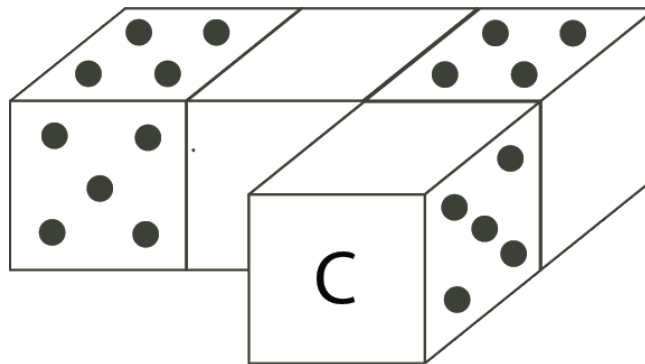

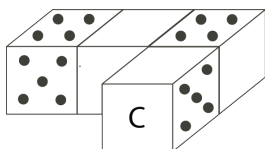

Problem of the Week

Problem C and Solution

Face to Face

Problem

A regular six-sided die has faces labelled with 1, 2, 3, 4, 5, and 6 dots. The number of dots on opposite faces add to seven. For example, the face with 2 dots is opposite the face with 5 dots. The four regular dice shown have been placed so that, for any two adjacent dice, the number of dots on the faces that are facing each other always add to nine. How many dots are on the face labelled C ?

Solution

We will separate the four dice and refer to them as in the following diagram:

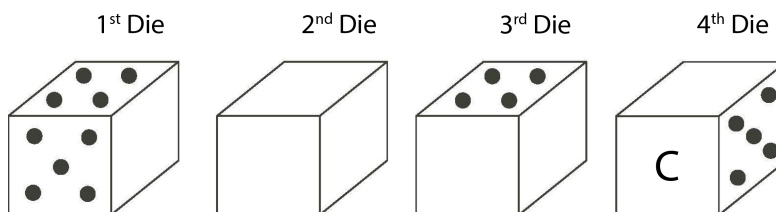

On the first die, since 5 dots are on the front, there are 2 dots on the back. Since 4 dots are on the top, there are 3 dots on the bottom. That leaves the faces with 1 and 6 dots for the sides. Since the number of dots on the sides facing each other add to 9, the right side of the first die must have 6 dots. If it were the face with 1 dot, the left face of the second die would have to have 8 dots, and that is not possible. Therefore, the right side of the first die must have 6 dots.

This means that the left side of the second die must have 3 dots, since the number of dots on the sides facing each other add to 9. Since the left side of the second die has 3 dots, then the right side of the second die must have 4 dots, since the number of dots on opposite sides add to 7.

Then the left side of the third die must have 5 dots. If there are 5 dots on the left side, then there must be 2 dots on the right side. Since there are 4 dots on the top of the third die, there must be 3 dots on the bottom. That leaves 1 and 6 dots for the front and back of the third die. The front must have 6 dots in order for the number of dots on the front of the third die and the back of the fourth die to total to 9.

Since the front of the third die has 6 dots, the back of the fourth die must have 3 dots. If the back of the fourth die has 3 dots, then the front of the fourth die must have 4 dots. But the front of the fourth die is labelled C . Therefore, there are 4 dots on the face labelled C .



Problème de la semaine

Problème C

Jeu de 100 cartes (1)

Dans un jeu de 100 cartes, les cartes sont numérotées de 1 à 100. Le nombre associé à une carte paraît sur les deux côtés de la carte. Chaque carte est rouge d'un côté et jaune de l'autre.

Sarai place toutes les cartes sur la table, côtés rouges vers le haut. Elle retourne d'abord chaque carte portant un nombre qui est un multiple de 2. Elle retourne ensuite chaque carte portant un nombre qui est un multiple de 3.

Après que Sarai eut fini de retourner les cartes, combien de cartes sont disposées côté rouge vers le haut?





1

Problem of the Week**Problem C and Solution****Hundred Deck 1****Problem**

Hundred Deck is a deck consisting of 100 cards numbered from 1 to 100. Each card has the same number printed on both sides. One side of the card is red and the other side of the card is yellow.

Sarai places all of the cards on a table with each card's red side facing up. She first flips over every card that has a number on it which is a multiple of 2. She then flips over every card that has a number on it which is a multiple of 3.

After Sarai has finished, how many cards have their red side facing up?

Solution

After flipping over all of the cards with numbers that are multiples of 2, 50 cards have their red side facing up and 50 cards have their yellow side facing up. All of the cards with their red side facing up are numbered with an odd number. All of the cards with their yellow side facing up are numbered with an even number.

Next, in the second round of flips, Sarai flips over every card that is numbered with a multiple of 3. Let's look at how many cards with their red side facing up will be flipped over to yellow and how many cards with their yellow side facing up will be flipped over to red.

There are 33 multiples of 3 from 1 to 100. They are

$$3, 6, 9, 12, 15, \dots, 87, 90, 93, 96, 99$$

Of these numbers, 17 are odd and 16 are even. The 17 odd multiples of 3 currently have their red side facing up, and therefore are flipped over to yellow. The 16 even multiples of 3 currently have their yellow side facing up, and are therefore flipped over to red (again).

So, after the first flip there were 50 cards with their red side facing up and 50 cards with their yellow side facing up. Of the 50 red, 17 were flipped to yellow. Of the 50 yellow, 16 were flipped to red. Therefore, after Sarai has finished, $50 - 17 + 16 = 49$ cards have their red side facing up.



Problème de la semaine

Problème C

Entretien de pelouse

Monsieur Gazon est une entreprise spécialisée dans l'entretien des pelouses. Pour tondre les pelouses, ils utilisent à la fois un tracteur à gazon et une tondeuse. Pour une pelouse donnée, l'entreprise prend 3 heures pour la tondre en utilisant uniquement la tondeuse et 40 minutes en utilisant uniquement le tracteur à gazon.

Un jour, le tracteur à gazon est tombé en panne après que 90 % de la pelouse eut été tondu. L'entreprise a donc dû tondre le restant de la pelouse à l'aide de la tondeuse.

En combien de minutes l'entreprise a-t-elle tondu toute la pelouse?

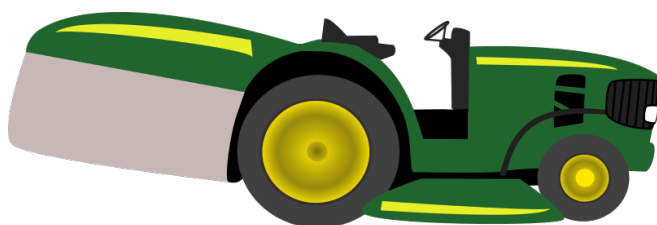



Problem of the Week

Problem C and Solution

Lawn Care



Problem

Lawns 'R' Us is a company that specializes in lawn care. When mowing lawns, they use both a powerful riding lawn mower and a push lawn mower. For a certain lawn, it takes the company 3 hours to cut the entire lawn using the push lawn mower only, and 40 minutes to cut the entire lawn using the powerful riding lawn mower only.

One day, the powerful riding lawn mower broke down after 90% of the lawn was cut. The remainder was then cut using the push lawn mower.

How many minutes did it take the company to cut the entire lawn?

Solution

It takes the company 40 minutes to cut 100% of the lawn with the powerful riding lawn mower. Therefore, it would take 90% of 40 minutes or $0.90 \times 40 = 36$ minutes to cut 90% of the lawn with the powerful riding lawn mower.

Since 90% of the lawn is cut with the powerful riding lawn mower, then $100\% - 90\% = 10\%$ of the lawn remains to be cut with the push lawn mower. It takes 3 hours or $3 \times 60 = 180$ minutes to cut 100% of the lawn with the push lawn mower. Therefore, it would take $0.10 \times 180 = 18$ minutes to cut 10% of the lawn with the push lawn mower.

Therefore, it would take a total of $36 + 18 = 54$ minutes to cut the entire lawn using the powerful riding lawn mower for 90% of the job and the push lawn mower for 10% of the job.



Problème de la semaine

Problème C

En moyenne

Quatre nombres entiers positifs différents ont une moyenne de 100. Si la différence positive entre le plus grand nombre entier et le plus petit nombre entier est aussi grande que possible, détermine la moyenne des deux autres nombres entiers.

PROBLÈME SUPPLÉMENTAIRE: Peux-tu résoudre le rébus ci-dessous?

LÉGÈREMENT
MOYENNE



SLIGHTLY AVERAGE

Problem of the Week

Problem C and Solution

Average Out

Problem

Four different positive integers have a mean (average) of 100. If the positive difference between the smallest and largest of these integers is as large as possible, determine the average of the other two integers.

EXTRA PROBLEM: Can you interpret the picture puzzle above?

Solution

Let a , b , c , and d represent four distinct positive integers such that $a < b < c < d$.

Since the average of the four positive integers is 100, their sum can be determined by multiplying their average by 4. Therefore, the sum of the numbers is $4 \times 100 = 400$. That is, $a + b + c + d = 400$.

For the difference between the largest integer and the smallest integer to be as large as possible, we want the smallest integer, a , to be as small as possible. The smallest positive integer is 1, so $a = 1$.

Since the sum of the four positive integers is 400 and the smallest integer, a , is 1, the sum of the remaining three integers is $b + c + d = 400 - 1 = 399$.

For the difference between the largest integer and the smallest integer to be as large as possible, we also want the largest integer, d , to be as large as possible. For d to be as large as possible, b and c must be as small as possible. The two positive integers, b and c , must be different and cannot equal 1, since $a = 1$. Therefore, $b = 2$ and $c = 3$, the smallest two remaining distinct positive integers. It follows that d , the largest of the four positive integers, is $399 - 2 - 3 = 394$. (This was not required but has been provided for completeness.)

The average of the middle two positive integers, b and c , is $\frac{2+3}{2} = \frac{5}{2} = 2.5$.

EXTENSION:

How would your answer change if it was also required that the average of b and c was an integer greater than or equal to 3?

EXTRA PROBLEM ANSWER: Slightly above average.



Problème de la semaine

Problème C

Chaque chose à sa place 1

- (a) Un diagramme de Venn comporte deux cercles, soit les cercles A et B. Chaque cercle contient des nombres entiers qui répondent aux critères suivants.

A: Inférieur à $-\frac{7}{61}$
B: Supérieur à $-\frac{1}{4}$

La région au milieu, créée par le chevauchement des deux cercles, contient des entiers qui sont compris à la fois dans A et B tandis que la région à l'extérieur des deux cercles contient des entiers qui ne sont ni dans A ni dans B.

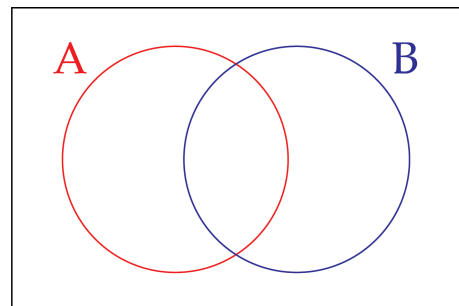

Au total, ce diagramme de Venn comporte quatre régions. Place des entiers dans autant de régions que tu le peux. Est-il possible de trouver un entier pour chaque région?

- (b) Un diagramme de Venn comporte trois cercles, soit les cercles A, B et C. Chaque cercle contient des couples d'entiers qui répondent aux critères suivants.

A: Leur somme est négative
B: Leur produit est négatif
C: Leur différence est paire

Au total, ce diagramme de Venn comporte huit régions. Place des couples d'entiers dans autant de régions que tu le peux. Est-il possible de trouver un couple d'entiers pour chaque région?

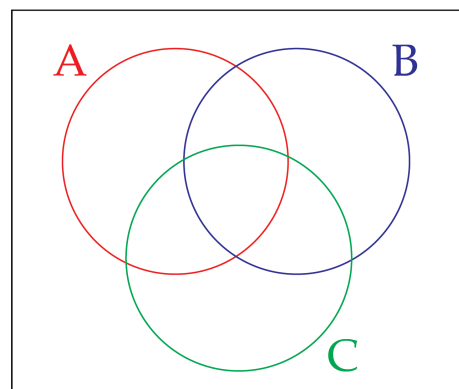



Problem of the Week

Problem C and Solution

Everything in its Place 1

Problem

- (a) A Venn diagram has two circles, labelled A and B. Each circle contains integers that satisfy the following criteria.

A: Less than $-\frac{7}{6}$

B: Greater than $-\frac{1}{4}$

The overlapping region in the middle contains integers that are in both A and B, and the region outside both circles contains integers that are neither in A nor B. In total this Venn diagram has four regions. Place integers in as many of the regions as you can. Is it possible to find an integer for each region?

- (b) A Venn diagram has three circles, labelled A, B, and C. Each circle contains pairs of integers that satisfy the following criteria.

A: Their sum is negative

B: Their product is negative

C: Their difference is even

In total this Venn diagram has eight regions. Place pairs of integers in as many of the regions as you can. Is it possible to find a pair of integers for each region?

Solution

- (a) We have marked the four regions W, X, Y, and Z.

We plot the given fractions on a number line as a reference:

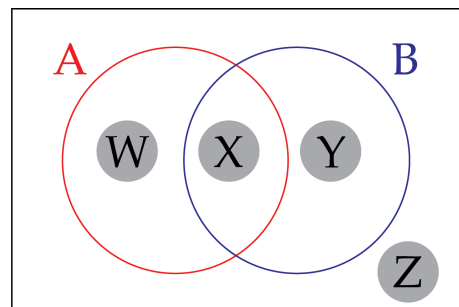
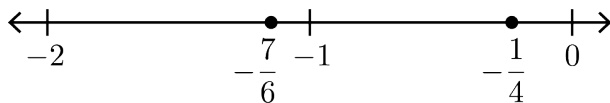

- Any integer in region W must be less than $-\frac{7}{6}$ and *not* greater than $-\frac{1}{4}$. This means the integer must be less than $-\frac{7}{6}$ and less than or equal to $-\frac{1}{4}$. Any integer less than or equal to -2 will satisfy this. Some examples are -2 , -3 , and -10 .
- Any integer in region X must be less than $-\frac{7}{6}$ and greater than $-\frac{1}{4}$. It is not possible to find such an integer so this region must remain empty.
- Any integer in region Y must be greater than $-\frac{1}{4}$ and *not* less than $-\frac{7}{6}$. This means the integer must be greater than $-\frac{1}{4}$ and greater than or equal to $-\frac{7}{6}$. Any integer greater than or equal to 0 will satisfy this. Some examples are 0 , 1 , and 30 .
- Any integer in region Z must be *not* less than $-\frac{7}{6}$ and *not* greater than $-\frac{1}{4}$. This means the integer must be greater than or equal to $-\frac{7}{6}$ and less than or equal to $-\frac{1}{4}$. The only integer that satisfies this is -1 .



- (b) We have marked the eight regions S, T, U, V, W, X, Y, and Z. It is helpful if we first think about the pairs of integers that each circle could contain. Two integers have a negative sum if they are both negative, or they have different signs and the negative number is larger in magnitude than the positive number. Two integers have a negative product if they have different signs. Two integers have an even difference if they are both even or both odd, regardless of their signs, and regardless of which number is being subtracted from the other.

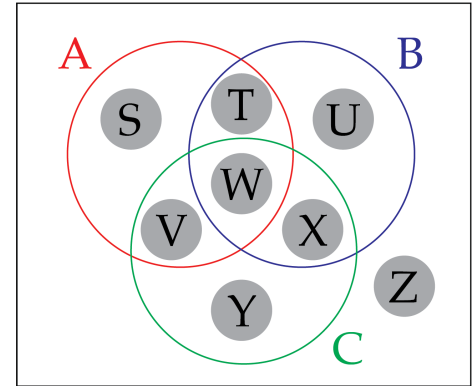

- Any pair of integers in region S must have a negative sum, a positive product, and an odd difference. This means they must both be negative, and one must be even and the other must be odd. One example is -5 and -6 , because $(-5) + (-6) = -11 < 0$, $(-5) \times (-6) = 30 > 0$, and $(-5) - (-6) = 1$, which is odd.
- Any pair of integers in region T must have a negative sum, a negative product, and an odd difference. This means they must have different signs, and the negative number must be larger in magnitude than the positive number. Also one number must be even and the other must be odd. One example is 3 and -8 , because $3 + (-8) = -5 < 0$, $3 \times (-8) = -24 < 0$, and $3 - (-8) = 11$, which is odd.
- Any pair of integers in region U must have a positive sum, a negative product, and an odd difference. This means they must have different signs, and the positive number must be larger in magnitude than the negative number. Also one number must be even and the other must be odd. One example is 8 and -3 , because $8 + (-3) = 5 > 0$, $8 \times (-3) = -24 < 0$, and $8 - (-3) = 11$, which is odd.
- Any pair of integers in region V must have a negative sum, a positive product, and an even difference. This means they must both be negative, and they must be either both even or both odd. One example is -4 and -6 , because $(-4) + (-6) = -10 < 0$, $(-4) \times (-6) = 24 > 0$, and $(-4) - (-6) = 2$, which is even.
- Any pair of integers in region W must have a negative sum, a negative product, and an even difference. This means they must have different signs, and the negative number must be larger in magnitude than the positive number. Also they must be either both even or both odd. One example is 2 and -8 , because $2 + (-8) = -6 < 0$, $2 \times (-8) = -16 < 0$, and $2 - (-8) = 10$, which is even.
- Any pair of integers in region X must have a positive sum, a negative product, and an even difference. This means they must have different signs, and the positive number must be larger in magnitude than the negative number. Also they must be either both even or both odd. One example is 8 and -2 , because $8 + (-2) = 6 > 0$, $8 \times (-2) = -16 < 0$, and $8 - (-2) = 10$, which is even.
- Any pair of integers in region Y must have a positive sum, a positive product, and an even difference. This means they must both be positive, and either both even or both odd. One example is 5 and 3 , because $5 + 3 = 8 > 0$, $5 \times 3 = 15 > 0$, and $5 - 3 = 2$, which is even.
- Any pair of integers in region Z must have a positive sum, a positive product, and an odd difference. This means they must both be positive, and one must be even and the other must be odd. One example is 5 and 4 , because $5 + 4 = 9 > 0$, $5 \times 4 = 20 > 0$, and $5 - 4 = 1$, which is odd.



Problème de la semaine

Problème C

Un carré dans un carré

Dans la figure ci-dessous, $PQRS$ est un carré. Les points T , U , V et W sont respectivement situés sur les côtés PQ , QR , RS et ST , et forment le carré $TUVW$.

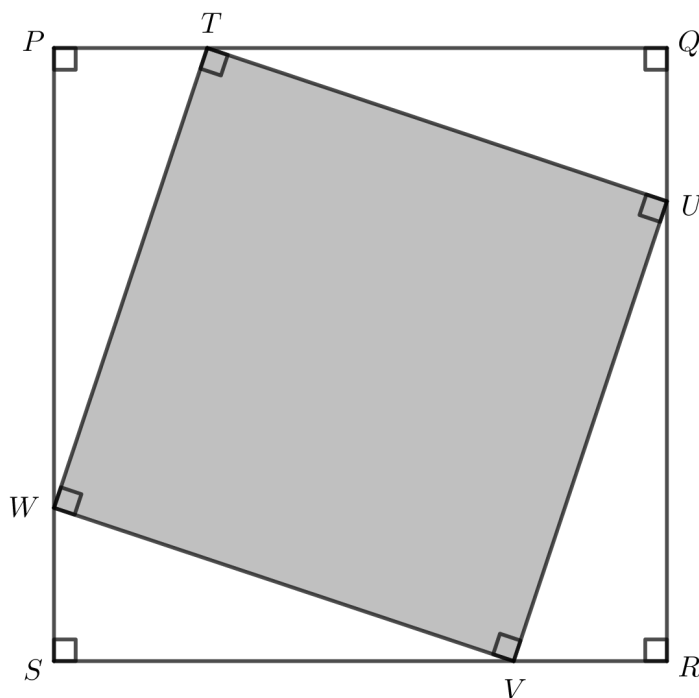

Si $PT = QU = RV = SW = 4$ m et que $PQRS$ a une aire de 256 m², détermine l'aire de $TUVW$.

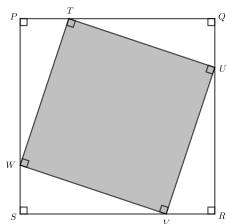

Problem of the Week

Problem C and Solution

A Square in a Square

Problem

In the diagram, $PQRS$ is a square. Points T , U , V , and W are on sides PQ , QR , RS , and ST , respectively, forming square $TUVW$.

If $PT = QU = RV = SW = 4$ m and $PQRS$ has area 256 m², determine the area of $TUVW$.

Solution

The area of square $PQRS$ is 256 m². Therefore, square $PQRS$ has side length equal to 16 m, since $16 \times 16 = 256$ and the area of a square is the product of its length and width.

We are given that $PT = QU = RV = SW = 4$ m. Since $16 - 4 = 12$, we know that $TQ = UR = VS = WP = 12$ m.

We add this information to the diagram.

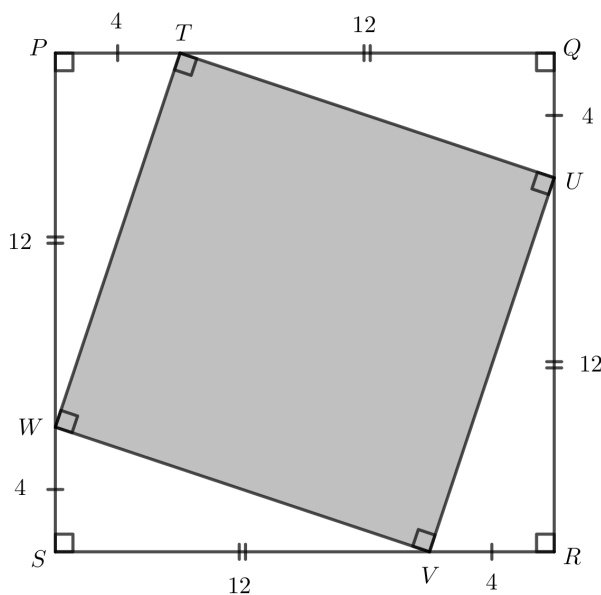

From this point, we will present two different solutions that calculate the area of square $TUVW$.

Solution 1

In $\triangle WPT$, $PT = 4$ and $WP = 12$. Also, this triangle is right-angled, so we can use one of PT and WP as the base and the other as the height in the calculation of the area of the triangle, since they are perpendicular to each other. Therefore,



the area of $\triangle WPT$ is equal to $\frac{PT \times WP}{2} = \frac{4 \times 12}{2} = 24 \text{ m}^2$. Since the triangles $\triangle WPT$, $\triangle TQU$, $\triangle URV$, and $\triangle VSW$ each have the same base length and height, their areas are equal. Therefore, the total area of the four triangles is $4 \times 24 = 96 \text{ m}^2$.

The area of square $TUVW$ can be determined by subtracting the area of the four triangles from the area of square $PQRS$.

Therefore, the area of square $TUVW$ is $256 - 96 = 160 \text{ m}^2$.

Solution 2

Some students may be familiar with the Pythagorean Theorem. This theorem states that in a right-angled triangle, the square of the length of the hypotenuse (the longest side) is equal to the sum of the squares of the other two sides. The longest side is located opposite the right angle.

$\triangle WPT$ is a right-angled triangle with $PT = 4$, $WP = 12$, and TW is the hypotenuse. Therefore,

$$\begin{aligned} TW^2 &= PT^2 + WP^2 \\ &= 4^2 + 12^2 \\ &= 16 + 144 \\ &= 160 \end{aligned}$$

Taking the square root, we have $TW = \sqrt{160} \text{ m}$, since $TW > 0$.

Now $TUVW$ is a square. Therefore, all of its side lengths are equal to $\sqrt{160}$. The area of $TUVW$ is calculated by multiplying its length by its width.

Therefore, the area of $TUVW$ is equal to $\sqrt{160} \times \sqrt{160} = 160 \text{ m}^2$.

Note: Alternatively, we could have found the area of square $TUVW$ by noticing that the area of a square is s^2 , where s is the side length of the square. For square $TUVW$, $s = TW$, and therefore the area is $s^2 = TW^2$. Now, from the Pythagorean Theorem above, we see $TW^2 = 160 \text{ m}^2$. Therefore, the area is 160 m^2 .



Problème de la semaine

Problème C

Ballons

Liang a cinq ballons qui sont identiques, à l'exception de leur couleur. Trois sont rouges (soit les ballons R) et deux sont verts (soit les ballons V). Il veut disposer les cinq ballons en rang mais il n'est pas encore sûr de l'ordre dans lequel il veut les aligner. De combien de façons différentes peut-il disposer les cinq ballons en rang?

L'un des ordres possibles est illustré ci-dessous.

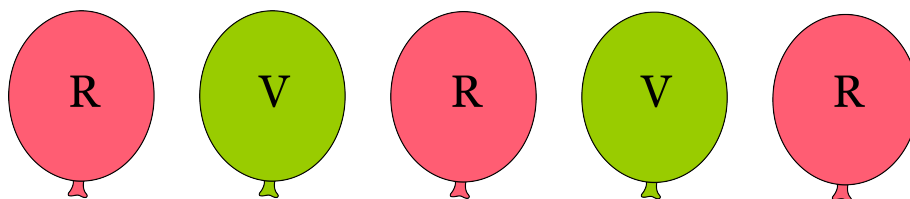

REMARQUE: Le fait d'échanger deux ballons rouges dans la disposition ordonnée ci-dessus ne résulte pas en une nouvelle disposition distincte car tous les ballons rouges sont identiques.

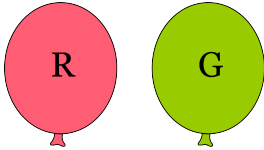

Problem of the Week

Problem C and Solution

Balloons

Problem

Liang has five balloons that are identical, except for their colour. Three are red (each labelled with an R) and two are green (each labelled with a G). He wants to put the five balloons in a row, but he is not sure which order he likes the best. How many different ways are there to arrange the five balloons in a row?

Solution

We will consider the following cases:

1. If the first balloon is green, then there are four positions where the second green balloon could go. Once the green balloons are placed, the remaining three balloons must be red. Therefore, there are 4 ways to arrange the balloons so that the first balloon is green.
2. If the first balloon is red and the second balloon is green, then there are three positions where the second green balloon could go. Once the green balloons are placed, the remaining balloons must be red. Therefore, there are 3 ways to arrange the balloons so that the first balloon is red and the second balloon is green.
3. If the first two balloons are red and the third balloon is green, then there are two positions where second green balloon could go. Once the green balloons are placed, the remaining balloon must be a red balloon. Therefore, there are 2 ways to arrange the balloons so that the first two balloons are red and the third balloon is green.
4. If the first three balloons are red and the fourth balloon is green, then the fifth balloon must be the second green balloon. Therefore, there is only 1 way to arrange the balloons so that the first three balloons are red and the fourth balloon is green.

There are no other cases to consider. The total number of ways to arrange the balloons is the sum of the number of ways from each of the cases. Therefore, there are $4 + 3 + 2 + 1 = 10$ ways to arrange the balloons in a row.



Problème de la semaine

Problème C

Bonbons surprises!

Ru a 100 bonbons qu'elle place dans des petites boîtes pour un jeu lors d'une fête. Elle a décidé que chaque boîte doit contenir au moins un bonbon et que deux boîtes ne peuvent pas contenir le même nombre de bonbons. De plus, aucune boîte ne peut être placée à l'intérieur d'une autre boîte.

Détermine le nombre maximum de boîtes qu'elle peut utiliser pour ses bonbons.

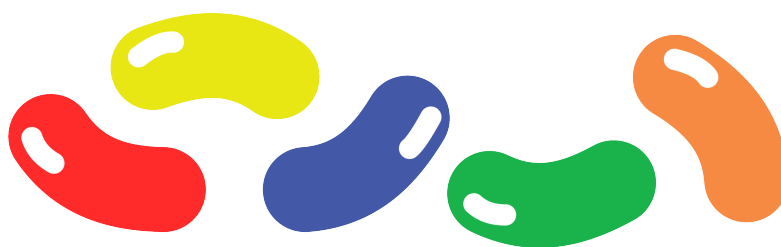



Problem of the Week

Problem C and Solution

Jellybean Surprise

Problem

Ru has 100 jellybeans that she is placing in small boxes for a party game. She has decided that each box must contain at least one jellybean and no two boxes can contain the same number of jellybeans. As well, no box can go inside any other box.

Determine the maximum number of boxes Ru can use for her jellybeans.

Solution

In order to maximize the number of boxes, each box must contain the smallest number of jellybeans possible. However, no two boxes can contain the same number of jellybeans. The simplest way to approach this problem is to put one jellybean in the first box and then let the number of jellybeans in each box after that be one more than the number of jellybeans in the box before it, until all 100 jellybeans are in boxes.

We will put 1 jellybean in the first box, 2 jellybeans in the second box, 3 jellybeans in the third box, and so on. After filling 12 boxes this way, we have used $1 + 2 + 3 + 4 + 5 + 6 + 7 + 8 + 9 + 10 + 11 + 12 = 78$ jellybeans. After putting 13 jellybeans in the thirteenth box, we have used $78 + 13 = 91$ jellybeans. There are 9 jellybeans left, but we already have a box containing 9 jellybeans. The remaining 9 jellybeans must therefore be distributed among the existing boxes while maintaining the condition that no two boxes contain the same number of jellybeans.

One way to do this is to put the 9 jellybeans in the last box which already contains 13 jellybeans. This would mean that the final box would contain $13 + 9 = 22$ jellybeans. Another solution is to increase the number of jellybeans in each of the final nine boxes by one jellybean each. This solution is summarized in the following table.

Box Number	1	2	3	4	5	6	7	8	9	10	11	12	13
Number of Jellybeans	1	2	3	4	6	7	8	9	10	11	12	13	14

Either way, the maximum number of boxes required is 13.

If you had 14 boxes, with the first box containing 1 jellybean and each box after that containing one more jellybean than the box before, you would need $1 + 2 + 3 + \dots + 13 + 14 = 105$ jellybeans, which is more than the number of jellybeans Ru has.



Problème de la semaine

Problème C

Carré magique

Les 9 premiers nombres entiers impairs positifs sont placés dans la grille 3×3 ci-contre de manière que les entiers de chaque rangée, de chaque colonne et des deux diagonales principales aient la même somme. Quatre nombres sont déjà placés dans la grille tandis que les cinq autres nombres sont représentés par les lettres A , B , C , D et E .

Détermine les valeurs de A , B , C , D et E .

A	5	B
C	D	17
11	13	E



A	5	B
C	D	17
11	13	E

Problem of the Week

Problem C and Solution

Odd Boxes

Problem

The first 9 positive odd integers are placed in the 3 by 3 grid in such a way that the sum of the numbers in each row, column and main diagonal is the same. Four of the numbers are shown and the other five numbers are represented by the letters A , B , C , D , and E .

Determine the values of A , B , C , D , and E .

Solution

The final answer is $A = 15$, $B = 7$, $C = 1$, $D = 9$, and $E = 3$, which we will justify below in two different ways.

Solution 1

The numbers to be placed in the grid are 1, 3, 5, 7, 9, 11, 13, 15, and 17, the first 9 positive odd integers. Therefore, the sum of all of the numbers in the grid is $1 + 3 + 5 + 7 + 9 + 11 + 13 + 15 + 17 = 81$. It follows that the sum of the sums of the three rows is 81. But each row has the same sum, so the sum of the numbers in each row is $81 \div 3 = 27$. We know that the sum of the numbers in each row, column and diagonal is the same. Therefore, the sum of the numbers in each column is also equal to 27 and the sum of the numbers in each diagonal is also equal to 27.

We can now use this information to determine the values in each cell of the 3 by 3 grid. In the third row, we know that $11 + 13 + E = 27$ or $24 + E = 27$ and $E = 3$ follows. Here is the updated grid:

A	5	B
C	D	17
11	13	3

In the second column, we know that $5 + D + 13 = 27$ and $D = 9$ follows. Here is the updated grid:

A	5	B
C	9	17
11	13	3



In second row, we know that $C + 9 + 17 = 27$ and $C = 1$ follows. Here is the updated grid:

A	5	B
1	9	17
11	13	3

In the first column, we know that $A + 1 + 11 = 27$ and $A = 15$ follows. Here is the updated grid:

15	5	B
1	9	17
11	13	3

In the first row, we know that $15 + 5 + B = 27$ and $B = 7$ follows. Here is the updated grid:

15	5	7
1	9	17
11	13	3

Therefore, $A = 15$, $B = 7$, $C = 1$, $D = 9$, and $E = 3$. With these values, we can see that each of the first 9 positive odd integers appears in the grid, and indeed, the sum of the numbers in each row, column, and main diagonal is the same.

Solution 2

In this solution we will determine the unknown values without finding that the row, column, and diagonal sum is 27. This solution will use more algebra.

Since the sum of the numbers in the third row is equal to the sum of the numbers in the third column, we know that

$$\begin{aligned}11 + 13 + E &= B + 17 + E \\11 + 13 &= B + 17 \\B &= 7\end{aligned}$$

Again, since the sum of the numbers in the first row is equal to the sum of the numbers in the



first column, we know that

$$A + 5 + 7 = A + C + 11$$

$$5 + 7 = C + 11$$

$$C = 1$$

Here is the updated grid:

A	5	7
1	D	17
11	13	E

We also know that the two diagonals have the same sum, so we have

$$A + D + E = 7 + D + 11$$

$$A + E = 18$$

We have used the odd numbers 1, 5, 7, 11, 13, and 17. This leaves the odd numbers 3, 9 and 15 for A , D , and E . Since $A + E = 18$, A and E must be 3 and 15, in some order.

If $A = 3$ and $E = 15$, then the sum of the first row is $3 + 5 + 7 = 15$ and the sum of the third row is $11 + 13 + 15 = 39$. These sums are not the same. Therefore, $A = 3$ and $E = 15$ is not correct.

If $A = 15$ and $E = 3$, then the sum of the first row is $15 + 5 + 7 = 27$ and the sum of the third row is $11 + 13 + 3 = 27$. These sums are the same. Therefore, $A = 15$ and $E = 3$. This leaves $D = 9$.

Therefore, $A = 15$, $B = 7$, $C = 1$, $D = 9$, and $E = 3$. From here, one can easily show each row, column, and diagonal sums to 27, as we found in Solution 1.



Problème de la semaine

Problème C

Compter des pièces

Inaaya a un bocal de pièces de monnaie contenant uniquement des pièces de 5 cents, de 10 cents et de 25 cents. Remarque qu'un dollar vaut 100 cents.

Le rapport du nombre de pièces de 25 cents au nombre de pièces de 10 cents au nombre de pièces de 5 cents est de $9 : 3 : 1$. Les pièces de monnaie dans le bocal ont une valeur totale de 18,20 \$. Combien y a-t-il de pièces dans le bocal d'Inaaya?





Problem of the Week

Problem C and Solution

Counting Coins

Problem

Inaaya has a jar of coins containing only nickels, dimes, and quarters. A nickel is worth 5 cents, a dime is worth 10 cents, a quarter is worth 25 cents, and a dollar is worth 100 cents.

The ratio of the number of quarters to the number of dimes to the number of nickels in the jar is $9 : 3 : 1$. The total value of all the coins in the jar is \$18.20. How many coins does Inaaya have in her jar?

Solution

Solution 1

Suppose the jar contained 1 nickel. Then, using the ratio $9 : 3 : 1$, the jar would contain 9 quarters, 3 dimes, and 1 nickel, which is 13 coins in total. The value of the 13 coins would be $25 \times 9 + 10 \times 3 + 5 \times 1 = 260$ cents or \$2.60.

Since the coins in the jar are in the ratio $9 : 3 : 1$, then we can group the coins into sets of 9 quarters, 3 dimes, and 1 nickel, with each set containing 13 coins and having a value of \$2.60.

Since the total value of the coins in the jar is \$18.20 and $\frac{\$18.20}{\$2.60} = 7$, then there are 7 of these sets of coins. Since each set has 13 coins, then there is a total of $7 \times 13 = 91$ coins in the jar.

Solution 2

This solution uses algebra which may or may not be too advanced for the solver.

Suppose there are n nickels in the jar. Then, using the ratio $9 : 3 : 1$, the jar would contain $9n$ quarters, $3n$ dimes, and n nickels, which is $13n$ coins in total.

The value of the coins would be

$$25 \times 9n + 10 \times 3n + 5 \times n = 225n + 30n + 5n = 260n \text{ cents}$$

The total value of the coins in the jar is \$18.20, or 1820 cents. Therefore,

$$\begin{aligned} 260n &= 1820 \\ \frac{260n}{260} &= \frac{1820}{260} \\ n &= 7 \end{aligned}$$

Since there are $13n$ coins in the jar and $n = 7$, there is a total of $13 \times 7 = 91$ coins in the jar.



Solution 3

In this solution, we look at the possibilities for the number of nickels, and systematically increase the number of nickels until the conditions in the problem are satisfied with that number of nickels. This solution is presented in a table.

Number of nickels	Number of quarters	Number of dimes	Number of coins	Total value of coins (in cents)
1	$9 \times 1 = 9$	$3 \times 1 = 3$	$1 + 9 + 3 = 13$	$1 \times 5 + 9 \times 25 + 3 \times 10 = 260$
2	$9 \times 2 = 18$	$3 \times 2 = 6$	$2 + 18 + 6 = 26$	$2 \times 5 + 18 \times 25 + 6 \times 10 = 520$
3	$9 \times 3 = 27$	$3 \times 3 = 9$	$3 + 27 + 9 = 39$	$3 \times 5 + 27 \times 25 + 9 \times 10 = 780$
4	$9 \times 4 = 36$	$3 \times 4 = 12$	$4 + 36 + 12 = 52$	$4 \times 5 + 36 \times 25 + 12 \times 10 = 1040$
5	$9 \times 5 = 45$	$3 \times 5 = 15$	$5 + 45 + 15 = 65$	$5 \times 5 + 45 \times 25 + 15 \times 10 = 1300$
6	$9 \times 6 = 54$	$3 \times 6 = 18$	$6 + 54 + 18 = 78$	$6 \times 5 + 54 \times 25 + 18 \times 10 = 1560$
7	$9 \times 7 = 63$	$3 \times 7 = 21$	$7 + 63 + 21 = 91$	$7 \times 5 + 63 \times 25 + 21 \times 10 = 1820$

From the table, we see that there is a total of 91 coins in the jar.



Problème de la semaine

Problème C

Une somme importante

Savais-tu que l'on peut exprimer le nombre 1000 comme la somme des 5 nombres entiers strictement positifs consécutifs dont le premier est 198? Autrement dit,

$$1000 = 198 + 199 + 200 + 201 + 202$$

De plus, on peut exprimer le nombre 1000 comme la somme des 16 nombres entiers strictement positifs consécutifs dont le premier est 55. Autrement dit,

$$1000 = 55 + 56 + 57 + 58 + 59 + 60 + 61 + 62 + 63 + 64 + 65 + 66 + 67 + 68 + 69 + 70$$

Il est également possible d'exprimer le nombre 1000 comme la somme de 25 nombres entiers strictement positifs consécutifs. Il s'agit du nombre maximum de nombres entiers strictement positifs consécutifs que l'on peut utiliser pour exprimer le nombre 1000 sous la forme d'une somme. Parmi les nombres entiers strictement positifs de cette somme, détermine celui qui est le plus petit.

1000



1000

Problem of the Week Problem C and Solution A Grand Sum

Problem

Did you know that 1000 can be written as the sum of the 5 consecutive positive integers beginning with 198? That is,

$$1000 = 198 + 199 + 200 + 201 + 202$$

Also, 1000 can be written as the sum of 16 consecutive positive integers beginning with 55. That is,

$$1000 = 55 + 56 + 57 + 58 + 59 + 60 + 61 + 62 + 63 + 64 + 65 + 66 + 67 + 68 + 69 + 70$$

It is also possible to write 1000 as a sum of 25 consecutive positive integers. This is the maximum number of consecutive positive integers that could be used to create the sum. Determine the smallest of the positive integers in this sum.

Solution

Solution 1

Let n , $n + 1$, $n + 2$, \dots , $n + 23$, and $n + 24$ represent the 25 consecutive positive integers. Then,

$$n + n + 1 + n + 2 + \dots + n + 23 + n + 24 = 1000$$

$$25n + (1 + 2 + 3 + \dots + 23 + 24) = 1000$$

$$25n + 300 = 1000$$

$$25n = 700$$

$$n = 28$$

Therefore, the smallest integer in the sum is 28.

Note: A useful fact that we can use is that the sum of the first n natural numbers can be calculated using the formula $\frac{n(n+1)}{2}$.

Using the formula with $n = 24$, the sum $1 + 2 + 3 + \dots + 23 + 24$ in the equation above can be quickly calculated as $\frac{24 \times 25}{2} = 300$.



Solution 2

Let n represent the middle integer of the 25 consecutive positive integers. Then there are 12 integers smaller than the middle integer, with the smallest integer being $(n - 12)$, and 12 integers larger than the middle integer, with the largest integer being $(n + 12)$.

Then, the sum of the 25 consecutive positive integers can be written as

$$(n - 12) + (n - 11) + \cdots + (n - 1) + n + (n + 1) + \cdots + (n + 11) + (n + 12)$$

This simplifies to $25n$, because for each positive integer 1 to 12 in the sum, the corresponding integer of opposite sign, -1 to -12 , also appears.

Thus, we have

$$\begin{aligned}25n &= 1000 \\n &= 40 \\n - 12 &= 28\end{aligned}$$

Therefore, the smallest integer in the sum is 28.

Solution 3

In this problem, we want to express 1000 as the sum of 25 consecutive positive integers. The average, $1000 \div 25 = 40$, is the middle integer in this sum. Solution 2 is a mathematical justification of this. There will be twelve consecutive integers above the average and twelve consecutive integers below the average. Therefore, the smallest integer in the sum is $40 - 12 = 28$.

Solution 4

Using the note that follows Solution 1, we know that the sum of the first 25 positive integers is

$$1 + 2 + 3 + \cdots + 24 + 25 = \frac{25 \times 26}{2} = 325$$

Now, if we add 1 to each term in the sum, we get

$2 + 3 + 4 + \cdots + 25 + 26 = 350$. Notice that the total increases by 25. In fact, every time we increase each term by 1, the total increases by 25.

The number of increases by 25 needed to get from 325 to 1000 is $\frac{1000-325}{25} = 27$.

Therefore, we will need 27 increases for each term, and so the smallest number in the sum is $1 + 27 = 28$.



Problème de la semaine

Problème C

En route

Une voiture et une moto ont quitté une station-service au même moment. Après avoir voyagé dans la même direction pendant une heure et quart, la voiture a parcouru 20 km de plus que la moto. Si la vitesse moyenne de la voiture était de 80 km/h, détermine la vitesse moyenne de la moto.

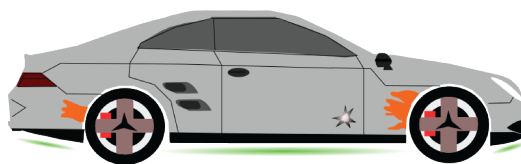



Problem of the Week

Problem C and Solution

Moving Along



Problem

A car and a motorcycle left a gas station at the same time. They each travelled in the same direction for one and one-quarter hours. At that time, the car had travelled 20 km farther than the motorcycle. If the average speed of the car was 80 km/h, determine the average speed of the motorcycle.

Solution

We can calculate distance travelled by multiplying the average speed by the time.

In one and one-quarter hours at 80 km/h, the car would travel

$$80 \times 1\frac{1}{4} = 80 \times \frac{5}{4} = 100 \text{ km.}$$

In the same time, the motorcycle travelled 20 km less. Therefore, the motorcycle has travelled $100 - 20 = 80$ km. Since the distance travelled is equal to the average speed multiplied by the time, then the average speed will equal the distance travelled divided by the time. Thus, the average speed of the motorcycle is equal to $80 \div 1\frac{1}{4} = 80 \div \frac{5}{4} = 80 \times \frac{4}{5} = 64$ km/h.

Therefore, the average speed of the motorcycle is 64 km/h.

Note: The calculations in this problem could be done using decimals by converting one and one-quarter hours to 1.25 hours.



Problème de la semaine

Problème C

Nombres entiers à somme gauche

Un nombre entier strictement positif de 3 chiffres est un nombre entier à *somme gauche* si la somme de ses deux chiffres les plus à gauche est égale à son chiffre le plus à droite.

Par exemple, le nombre 156 est un entier à somme gauche puisque $1 + 5 = 6$.

Combien y a-t-il de nombres entiers à somme gauche?

$$1 + 5 = 6$$



$$1 + 5 = 6$$

Problem of the Week

Problem C and Solution

Sum Left

Problem

A 3-digit positive integer is defined to be *sumleft* if the sum of its two leftmost digits is equal to its rightmost digit.

For example, the number 156 is sumleft since $1 + 5 = 6$.

How many sumleft integers are there?

Solution

From the definition, the hundreds and tens digits of a sumleft integer will determine the ones (units) digit, since the ones digit is equal to the sum of the first two digits.

Consider first those sumleft integers whose hundreds digit is 1. We enumerate through the possibilities for the tens digit to determine that the sumleft integers with hundreds digit 1 are 101, 112, 123, 134, 145, 156, 167, 178, and 189.

Therefore, there are 9 sumleft integers with hundreds digit 1.

We continue in this manner, and for each possible hundreds digit, we determine all the sumleft integers with that hundreds digit. We have organized this information in the table below.

Hundreds digit	Sumleft integers	Number of sumleft integers
1	101, 112, 123, 134, 145, 156, 167, 178, 189	9
2	202, 213, 224, 235, 246, 257, 268, 279	8
3	303, 314, 325, 336, 347, 358, 369	7
4	404, 415, 426, 437, 448, 459	6
5	505, 516, 527, 538, 549	5
6	606, 617, 628, 639	4
7	707, 718, 729	3
8	808, 819	2
9	909	1

Therefore, there are $9 + 8 + 7 + 6 + 5 + 4 + 3 + 2 + 1 = 45$ sumleft integers.



Problème de la semaine

Problème C

Somme de nombres premiers

Un *nombre premier* est un nombre entier strictement positif supérieur à 1 qui admet exactement deux diviseurs positifs, soit 1 et lui-même. Par exemple, le nombre 17 est un nombre premier car il n'admet que 1 et 17 comme diviseurs positifs..

Soit a , b , c et d quatre nombres premiers différents. Si $a \times b \times c \times d$ est égal à un nombre de trois chiffres dont le chiffre des dizaines est 1 et le chiffre des unités est 0, détermine toutes les valeurs possibles de $a + b + c + d$.

$$a+b+c+d=?$$



$$a+b+c+d=?$$

Problem of the Week

Problem C and Solution

Just Sum Primes

Problem

A *prime number* is an integer greater than 1 that has only two positive divisors: 1 and itself. The number 17 is prime because its only positive divisors are 1 and 17.

The variables a , b , c , and d represent four different prime numbers. If $a \times b \times c \times d$ is equal to a three-digit number with a tens digit of 1 and a ones (units) digit of 0, determine all the possible values of $a + b + c + d$.

Solution

Let e be the hundreds digit of the product $a \times b \times c \times d$. In other words, $a \times b \times c \times d = e10$.

Since $e10$ ends in 0, it must be divisible by 10, which is the product of the two primes 2 and 5. That tells us that 2 and 5 must be two of the prime numbers a , b , c , and d .

When $e10$ is divided by 10, the quotient is $e10 \div 10 = e1$. Since $e10$ is a three-digit number, $e \neq 0$ because $e10 = 010 = 10$ is not a three-digit number. Thus, the possibilities for $e1$ are 11, 21, 31, 41, 51, 61, 71, 81, and 91.

The two-digit number $e1$ must be the product of two distinct prime numbers, neither of which is 2 or 5. We can rule out any possibilities for $e1$ that are prime, since these numbers would have only one prime factor. Therefore, we can rule out 11, 31, 41, 61, and 71, which are all prime. The remaining possibilities for e are 2, 5, 8, and 9.

- If $e = 2$, then the two-digit number would be 21, which has prime factors 7 and 3. The four prime factors of $e10 = 210$ are 2, 3, 5, and 7, producing a sum of $2 + 3 + 5 + 7 = 17$.
- If $e = 5$, then the two-digit number would be 51, which has prime factors 17 and 3. The four prime factors of $e10 = 510$ are 2, 3, 5, and 17, producing a sum of $2 + 3 + 5 + 17 = 27$.
- If $e = 8$, then the two-digit number would be 81, but we cannot write 81 as the product of two distinct prime numbers. Note that $810 = 2 \times 3 \times 3 \times 3 \times 3 \times 5$, which is the product of six prime numbers not all of which are distinct. Therefore, 8 is not a possible value for e .
- If $e = 9$, then the two-digit number would be 91, which has prime factors 7 and 13. The four prime factors of $e10 = 910$ are 2, 5, 7, and 13, producing a sum of $2 + 5 + 7 + 13 = 27$. However, we already have the sum 27.

Since there are no other possible cases to consider, the only possible values of $a + b + c + d$ are 17 and 27.



Problème de la semaine

Problème C

Changeons de hauteur!

Le triangle ABC ci-dessous est acutangle. Le point M est choisi sur le segment AB de telle sorte que CM soit une hauteur du triangle ABC . De même, le point N est choisi sur le segment AC de telle sorte que BN soit une hauteur du triangle ABC .

Supposons que $CM = 32$ cm, $AB = 36$ cm et $AC = 40$ cm, quelle est la longueur de la hauteur BN ?

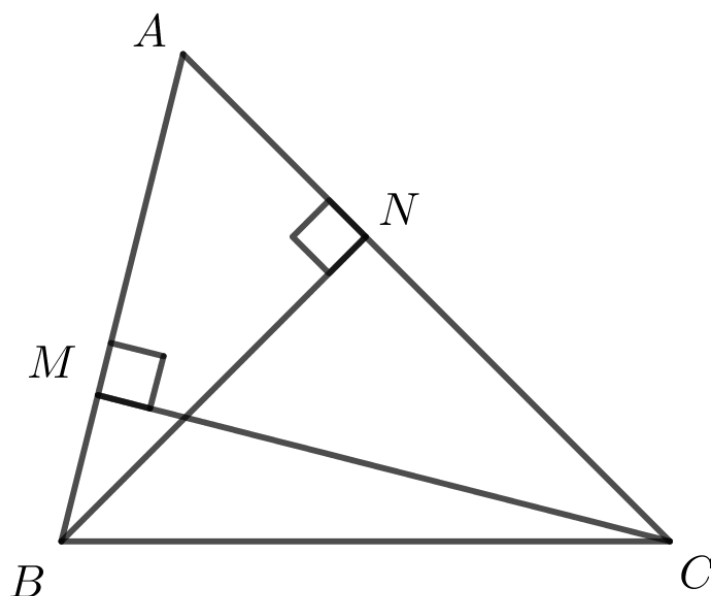

REMARQUE: Une hauteur d'un triangle est un segment de droite issu d'un sommet du triangle qui est perpendiculaire au côté opposé à ce sommet.

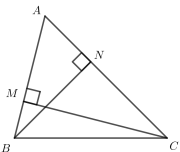

Problem of the Week

Problem C and Solution

Altitude Change

Problem

In acute $\triangle ABC$, two altitudes have been drawn in. Point M lies on AB so that CM is an altitude of $\triangle ABC$, and point N lies on AC so that BN is an altitude of $\triangle ABC$.

Suppose $CM = 32$ cm, $AB = 36$ cm, and $AC = 40$ cm. Determine the length of altitude BN .

Solution

The area of a triangle is determined using the formula

$$\text{area} = \frac{\text{base} \times \text{height}}{2}$$

The height of the triangle is the length of an altitude and the base of the triangle is the length of the side to which a particular altitude is drawn.

Thus,

$$\begin{aligned}\text{Area } \triangle ABC &= \frac{AB \times CM}{2} \\ &= \frac{36 \times 32}{2} \\ &= 576 \text{ cm}^2\end{aligned}$$

Also,

$$\begin{aligned}\text{Area } \triangle ABC &= \frac{AC \times BN}{2} \\ 576 &= \frac{40 \times BN}{2} \\ 1152 &= 40 \times BN \\ BN &= 28.8 \text{ cm}\end{aligned}$$

Therefore, the length of altitude BN is 28.8 cm.



Problème de la semaine

Problème C

Menu du jour

Jessica et Callista vont au restaurant-minute du coin. Elles veulent toutes les deux acheter le menu du jour. Jessica a $\frac{3}{4}$ de l'argent qu'il lui faut pour acheter le menu du jour tandis que Callista a la moitié de l'argent qu'il lui faut pour l'acheter. Si le menu du jour coûtait 3 \$ de moins, alors elles auraient exactement assez d'argent pour acheter deux menus du jour si elles mettaient leur argent en commun.

Quel est le prix initial du menu du jour?

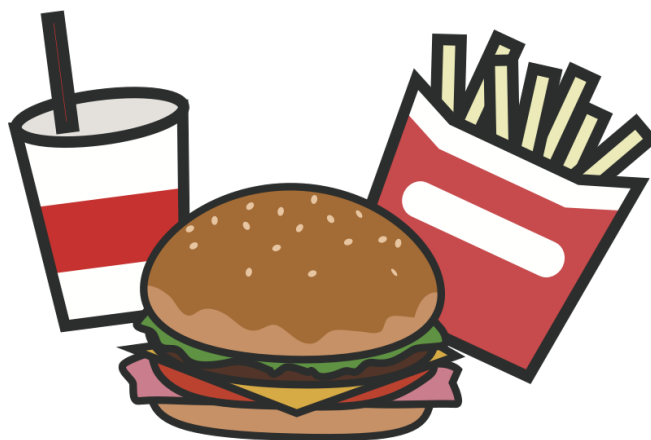

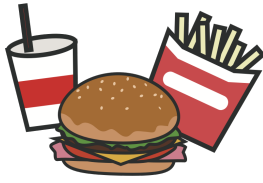

Problem of the Week

Problem C and Solution

Meal Deal

Problem

Jessica and Callista go to the local burger joint. They both want to buy the meal deal. Jessica has $\frac{3}{4}$ of the money needed to buy the meal deal and Callista has half of the money needed to buy the meal deal. If the meal deal was \$3 cheaper, then together they would have exactly enough money to buy two of the meal deals.

What is the original price of the meal deal?

Solution

Solution 1:

Suppose that the cost of the meal deal, in dollars, is C . Then Jessica has $\frac{3}{4}C$ and Callista has $\frac{1}{2}C$. Combining their money, together Jessica and Callista have

$$\frac{3}{4}C + \frac{1}{2}C = \frac{3}{4}C + \frac{2}{4}C = \frac{5}{4}C$$

If the meal deal was \$3 cheaper, then the cost to buy one meal deal would be $C - 3$. If the cost of one meal deal was $C - 3$, then the cost to buy two meal deals at this price would be $2(C - 3) = (C - 3) + (C - 3) = 2C - 6$.

Combined, Jessica and Callista would have enough money to buy exactly two meal deals at this reduced price. Thus, $2C - 6 = \frac{5}{4}C$.

Solving for C ,

$$\begin{aligned}2C - 6 &= \frac{5}{4}C \\2C - \frac{5}{4}C &= 6 \\ \frac{8}{4}C - \frac{5}{4}C &= 6 \\ \frac{3}{4}C &= 6 \\ 3C &= 24 \\ C &= 8\end{aligned}$$

Therefore, the original price of the meal deal is \$8.

**Solution 2:**

Since the new price of the meal deal is \$3 cheaper than the original price, then the original price must be more than \$3. We will use systematic trial and error to figure out the original price.

Suppose the original price of the meal deal was \$6. Then the reduced price would be \$3. Also, Jessica has $\frac{3}{4} \times \$6 = \4.50 and Callista has $\frac{1}{2} \times \$6 = \3 , and in total they have $\$4.50 + \$3 = \$7.50$. With \$7.50, they could buy exactly $7.50 \div 3 = 2.5$ meal deals at a price of \$3 each.

Suppose the original price of the meal deal was \$12. Then the reduced price would be \$9. Also, Jessica has $\frac{3}{4} \times \$12 = \9 and Callista has $\frac{1}{2} \times \$12 = \6 , and in total they have $\$9 + \$6 = \$15$. With \$15, they could buy $15 \div 9 \approx 1.67$ meal deals at a price of \$9 each.

We can see that the original price of the meal deal lies somewhere between \$6 and \$12.

Let's suppose the original price of the meal deal was \$8. Then the reduced price would be \$5. Also, Jessica has $\frac{3}{4} \times \$8 = \6 and Callista has $\frac{1}{2} \times \$8 = \4 , and in total they have $\$6 + \$4 = \$10$. With \$10, they could buy exactly $10 \div 5 = 2$ meal deals at a price of \$5 each.

Thus, we can see that the original price of the meal deal is \$8.

Géométrie et mesure (G)





Problème de la semaine

Problème C

Pentagone partitionné

Considérons le pentagone $PQRST$. On nomme les sommets P , Q , R , S et T en partant du coin supérieur gauche du pentagone et en faisant le tour du pentagone dans le sens inverse des aiguilles d'une montre.

Le pentagone a des angles droits à P , Q et R , des angles obtus à S et T , et une aire de 1000 cm^2 .

Le point V est situé à l'intérieur du pentagone de manière que les angles PTV , TVS et VSR soient des angles droits.

Le point U est situé sur TV tel que le triangle STU ait une aire de 210 cm^2 . De plus, $PQ = 50 \text{ cm}$, $SR = 15 \text{ cm}$ et $TU = 30 \text{ cm}$.

Déterminer la longueur de PT .

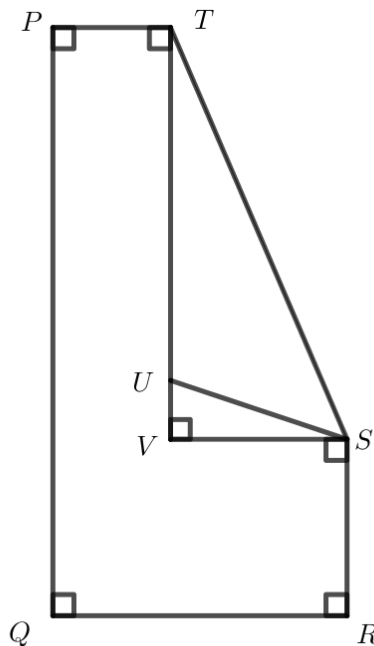

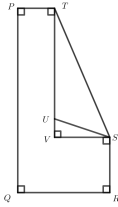

Problem of the Week

Problem C and Solution

Partitioned Pentagon

Problem

Consider pentagon $PQRST$. Starting at P and moving around the pentagon, the vertices are labelled P , Q , R , S , and T , in order. The pentagon has right angles at P , Q , and R , obtuse angles at S and T , and an area of 1000 cm^2 . Point V lies inside the pentagon such that $\angle PTV$, $\angle TVS$, and $\angle VSR$ are right angles. Point U lies on TV such that $\triangle STU$ has an area of 210 cm^2 . Also, it is known that $PQ = 50 \text{ cm}$, $SR = 15 \text{ cm}$, and $TU = 30 \text{ cm}$. Determine the length of PT .

Solution

Extend TV to meet QR at W . We mark this and all of the given information on the diagram.

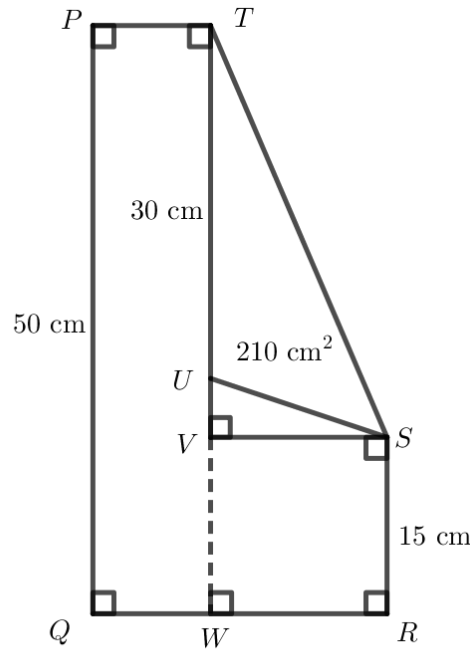

To find the area of a triangle, multiply the length of the base by the height and divide by 2. In $\triangle STU$, the base TU has length 30 cm. The corresponding height of $\triangle STU$ is the perpendicular distance from TU (extended) to vertex S , namely SV .



Since the area of $\triangle STU$ is given to be 210 cm^2 ,

$$210 = \frac{30 \times SV}{2}$$

$$210 = 15 \times SV$$

$$14 = SV$$

We know that $TW = PQ = 50$, $VW = SR = 15$, and $TW = TU + UV + VW$.

It follows that $50 = 30 + UV + 15$ and $UV = 5 \text{ cm}$.

Now we can relate the total area of the pentagon to the areas of the shapes inside.

$$\text{Area } PQRST = \text{Area } PQWT + \text{Area } RSVW + \text{Area } \triangle SUV + \text{Area } \triangle STU$$

$$1000 = PQ \times PT + SV \times SR + \frac{UV \times SV}{2} + 210$$

$$1000 = 50 \times PT + 14 \times 15 + \frac{5 \times 14}{2} + 210$$

$$1000 = 50 \times PT + 210 + 35 + 210$$

$$1000 = 50 \times PT + 455$$

$$1000 - 455 = 50 \times PT$$

$$545 = 50 \times PT$$

$$\frac{545}{50} = PT$$

Therefore, $PT = 10.9 \text{ cm}$.



Problème de la semaine

Problème C

Tout au carré

Ziibi a dessiné un carré. Il a nommé les sommets J , K , L et M en partant du coin supérieur gauche du carré et en faisant le tour du carré dans le sens des aiguilles d'une montre. Il a dessiné les points P et Q à l'extérieur du carré de manière que les triangles JMP et MLQ soient équilatéraux.

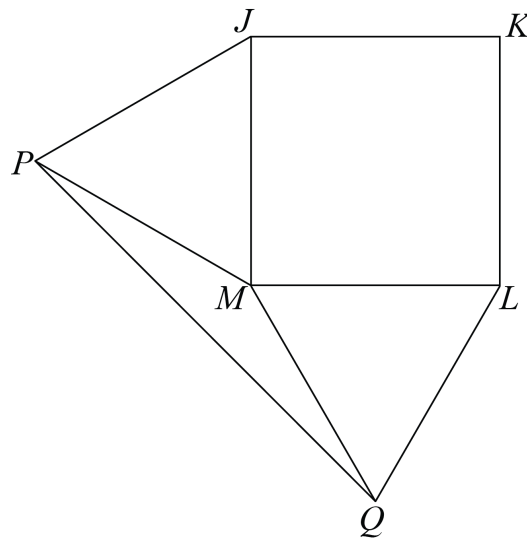

Détermine la mesure de l'angle MPQ en degrés.

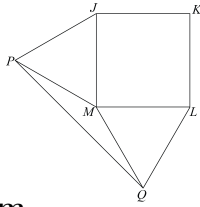

Problem of the Week

Problem C and Solution

All Squared Up

Problem

Ziibi drew a square. Starting at one corner and moving around the square, he labelled the vertices J , K , L , and M , in order. He drew points P and Q outside the square so that both $\triangle JPM$ and $\triangle MLQ$ are equilateral. Determine the measure, in degrees, of $\angle MPQ$.

Solution

Since $JKLM$ is a square, $JK = KL = LM = MJ$.

Since $\triangle JPM$ is equilateral, $MJ = JP = MP$.

Since $\triangle MLQ$ is equilateral, $LM = LQ = QM$.

It follows that

$$JK = KL = LM = MJ = JP = MP = LQ = QM.$$

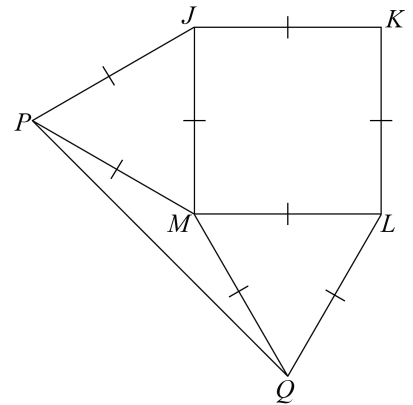

Each angle in a square is 90° . Therefore, $\angle JML = 90^\circ$.

Each angle in an equilateral triangle is 60° . Therefore, $\angle JPM = 60^\circ$ and $\angle LMQ = 60^\circ$.

A complete revolution is 360° . Since $\angle PMQ$, $\angle JPM$, $\angle JML$, and $\angle LMQ$ form a complete revolution, then

$$\begin{aligned}\angle PMQ &= 360^\circ - \angle JPM - \angle JML - \angle LMQ \\ &= 360^\circ - 60^\circ - 90^\circ - 60^\circ \\ &= 150^\circ\end{aligned}$$

In $\triangle MPQ$, $MP = QM$ and the triangle is isosceles. It follows that $\angle MPQ = \angle MQP$.

In a triangle, the sum of the three angles is 180° . Since $\angle PMQ = 150^\circ$, then the sum of the two remaining equal angles must be 30° . Therefore, each of the remaining two angles must equal 15° and it follows that $\angle MPQ = 15^\circ$.



Problème de la semaine

Problème C

Deux chemins

Les points R , S , T , U , V et W sont placés en ligne droite. Il existe deux chemins courbes qui mènent de R à W . Le chemin supérieur est un demi-cercle de diamètre RW . Le chemin inférieur est composé de cinq demi-cercles de diamètres RS , ST , TU , UV et VW .

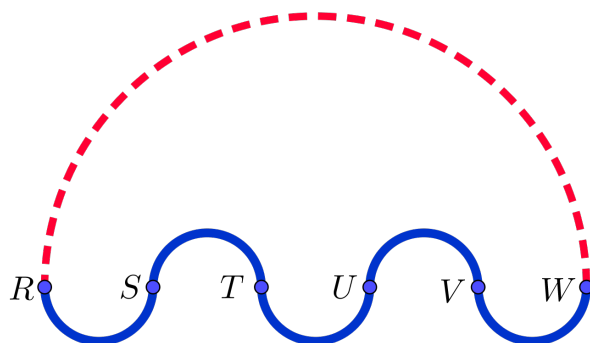

La distance en ligne droite de R à W est de 1000 m. De plus,
 $RS = ST = TU = UV = VW$.

John et Betty partent en même temps à partir du point R et roulent à vélo le long de ces chemins jusqu'au point W . Betty suit le chemin supérieur tandis que John suit le chemin inférieur. S'ils roulent à la même vitesse, lequel d'entre eux arrivera le premier au point W ?

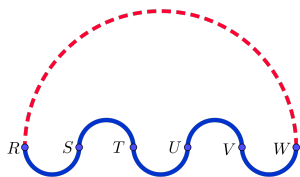

Problem of the Week

Problem C and Solution

Two Paths

Problem

Points R , S , T , U , V , and W lie in a straight line. There are two curved paths from R to W . The upper path is a semi-circle with diameter RW . The lower path is made up of five semi-circles with diameters RS , ST , TU , UV , and VW .

It is also known that the distance from R to W in a straight line is 1000 m, and $RS = ST = TU = UV = VW$.

Starting at the same time, John and Betty ride their bicycles along these paths from R to W . Betty follows the upper path and John follows the lower path. If they bike at the same speed, who will arrive at W first?

Solution

The circumference of a circle is found by multiplying its diameter by π . To find the circumference of a semi-circle, we divide its circumference by 2.

The length of the upper path is equal to half the circumference of a circle with diameter 1000 m. Therefore, the length of the upper path is equal to $\pi \times 1000 \div 2 = 500\pi$ m. (This is approximately 1570.8 m.)

Each of the semi-circles along the lower path have the same diameter. The diameter of each of these semi-circles is $1000 \div 5 = 200$ m. The length of the lower path is equal to half the circumference of five circles, each with diameter 200 m. Therefore, the distance along the lower path is equal to

$$5 \times (\pi \times 200 \div 2) = 5 \times (100\pi) = 500\pi \text{ m}$$

Since both John and Betty bike at the same speed and both travel the same distance, they will arrive at point W at the same time. The answer to the problem may surprise you.

EXTENSION:

If you were to extend the problem so that Betty travels the same route but John travels along a lower path made up of 100 semi-circles of equal diameter from R to W , they would still both travel exactly the same distance, 500π m. Check it out!



Problème de la semaine

Problème C

Un carré dans un carré

Dans la figure ci-dessous, $PQRS$ est un carré. Les points T , U , V et W sont respectivement situés sur les côtés PQ , QR , RS et ST , et forment le carré $TUVW$.

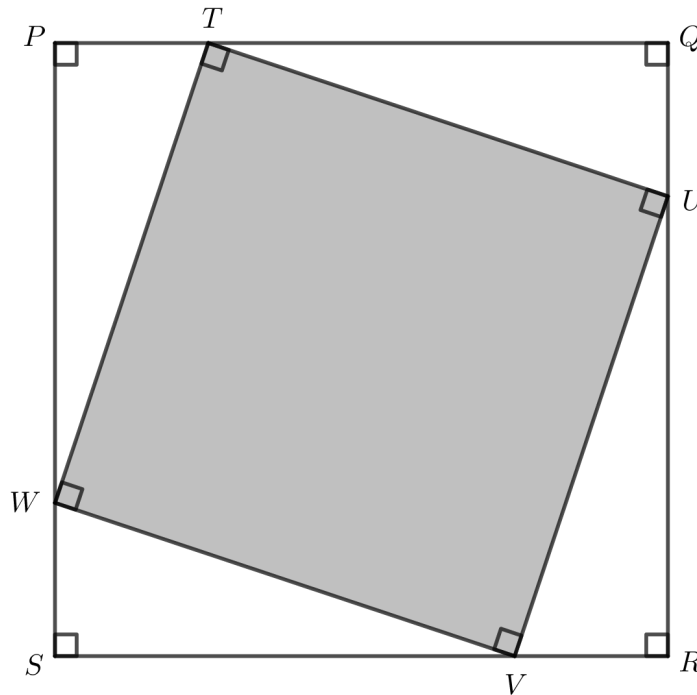

Si $PT = QU = RV = SW = 4$ m et que $PQRS$ a une aire de 256 m², détermine l'aire de $TUVW$.

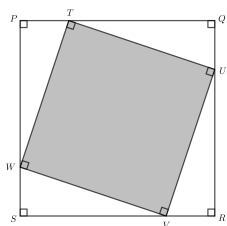

Problem of the Week

Problem C and Solution

A Square in a Square

Problem

In the diagram, $PQRS$ is a square. Points T , U , V , and W are on sides PQ , QR , RS , and ST , respectively, forming square $TUVW$.

If $PT = QU = RV = SW = 4$ m and $PQRS$ has area 256 m², determine the area of $TUVW$.

Solution

The area of square $PQRS$ is 256 m². Therefore, square $PQRS$ has side length equal to 16 m, since $16 \times 16 = 256$ and the area of a square is the product of its length and width.

We are given that $PT = QU = RV = SW = 4$ m. Since $16 - 4 = 12$, we know that $TQ = UR = VS = WP = 12$ m.

We add this information to the diagram.

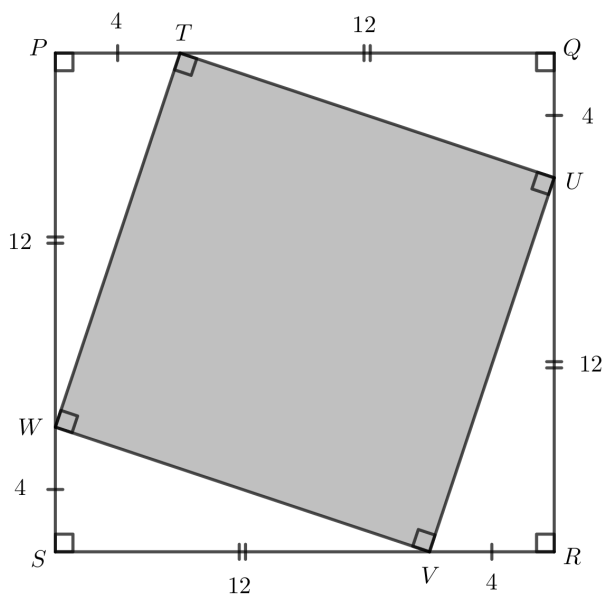

From this point, we will present two different solutions that calculate the area of square $TUVW$.

Solution 1

In $\triangle WPT$, $PT = 4$ and $WP = 12$. Also, this triangle is right-angled, so we can use one of PT and WP as the base and the other as the height in the calculation of the area of the triangle, since they are perpendicular to each other. Therefore,



the area of $\triangle WPT$ is equal to $\frac{PT \times WP}{2} = \frac{4 \times 12}{2} = 24 \text{ m}^2$. Since the triangles $\triangle WPT$, $\triangle TQU$, $\triangle URV$, and $\triangle VSW$ each have the same base length and height, their areas are equal. Therefore, the total area of the four triangles is $4 \times 24 = 96 \text{ m}^2$.

The area of square $TUVW$ can be determined by subtracting the area of the four triangles from the area of square $PQRS$.

Therefore, the area of square $TUVW$ is $256 - 96 = 160 \text{ m}^2$.

Solution 2

Some students may be familiar with the Pythagorean Theorem. This theorem states that in a right-angled triangle, the square of the length of the hypotenuse (the longest side) is equal to the sum of the squares of the other two sides. The longest side is located opposite the right angle.

$\triangle WPT$ is a right-angled triangle with $PT = 4$, $WP = 12$, and TW is the hypotenuse. Therefore,

$$\begin{aligned} TW^2 &= PT^2 + WP^2 \\ &= 4^2 + 12^2 \\ &= 16 + 144 \\ &= 160 \end{aligned}$$

Taking the square root, we have $TW = \sqrt{160} \text{ m}$, since $TW > 0$.

Now $TUVW$ is a square. Therefore, all of its side lengths are equal to $\sqrt{160}$. The area of $TUVW$ is calculated by multiplying its length by its width.

Therefore, the area of $TUVW$ is equal to $\sqrt{160} \times \sqrt{160} = 160 \text{ m}^2$.

Note: Alternatively, we could have found the area of square $TUVW$ by noticing that the area of a square is s^2 , where s is the side length of the square. For square $TUVW$, $s = TW$, and therefore the area is $s^2 = TW^2$. Now, from the Pythagorean Theorem above, we see $TW^2 = 160 \text{ m}^2$. Therefore, the area is 160 m^2 .



Problème de la semaine

Problème C

Je veux plus de cubes!

Rashid a un cube en bois dont les arêtes mesurent 10 cm. Il effectue trois coupes parallèles aux faces du cube afin de créer 8 cubes identiques plus petits, comme dans la figure ci-dessous.

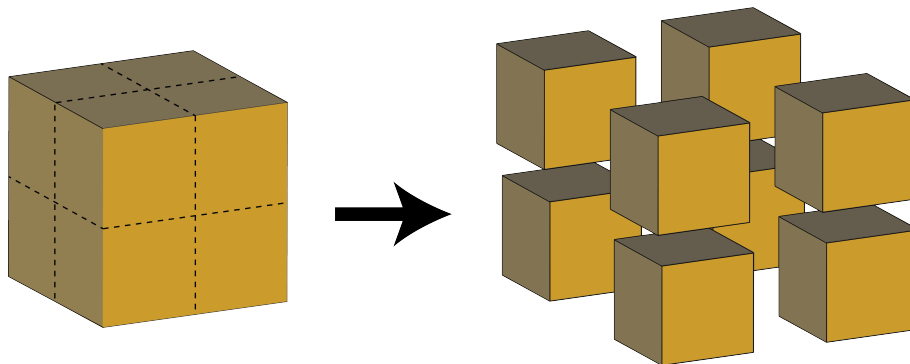

Quelle est la différence entre l'aire totale du cube initial et la somme des aires totales des 8 petits cubes?



Problem of the Week

Problem C and Solution

I Want More Cubes

Problem

Rashid has a wooden cube with a side length of 10 cm. He makes three cuts parallel to the faces of the cube in order to create 8 identical smaller cubes, as shown.

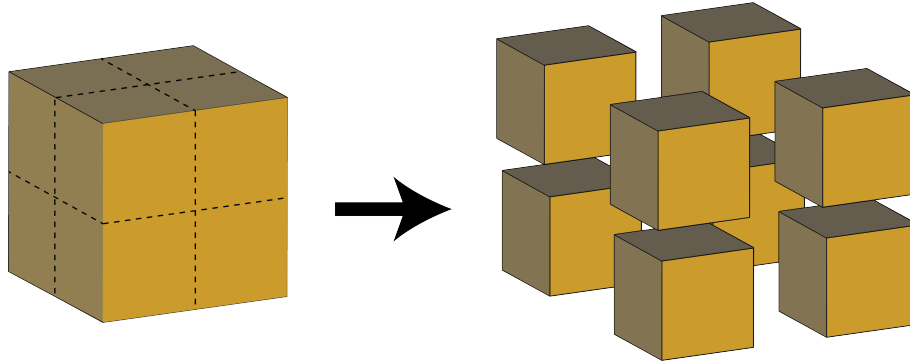

What is the difference between the surface area of the original cube and the total surface area of the 8 smaller cubes?

Solution

Solution 1

Each face on the original cube has an area of $10 \times 10 = 100 \text{ cm}^2$. Since there are 6 faces on a cube, the surface area of the original cube is $100 \times 6 = 600 \text{ cm}^2$.

Each of the smaller cubes has a side length of 5 cm. So the surface area of each smaller cube is $5 \times 5 \times 6 = 150 \text{ cm}^2$. There are 8 smaller cubes, so the total surface area of the smaller cubes is $8 \times 150 = 1200 \text{ cm}^2$.

Therefore, the difference in surface area is $1200 - 600 = 600 \text{ cm}^2$.

Solution 2

Each cut increases the surface area by two $10 \text{ cm} \times 10 \text{ cm}$ squares, or $2 \times 10 \times 10 = 200 \text{ cm}^2$.

Since there are three cuts, the increase in surface area is $3 \times 200 \text{ cm}^2 = 600 \text{ cm}^2$.



Problème de la semaine

Problème C

Un point à la fois

Priya dessine un polygone sur un morceau de bois. Elle commence par planter un clou dans le morceau de bois, qu'elle nomme le point O . Puis elle attache l'extrémité d'une ficelle au clou et l'autre extrémité à un crayon. Elle tend la ficelle au maximum et fait un point sur le morceau de bois, qu'elle nomme le point A . En gardant la ficelle tendue, elle la fait tourner de 20° dans le sens des aiguilles d'une montre et fait un autre point, qu'elle nomme le point B . Elle relie ensuite les points A et B par une ligne droite.

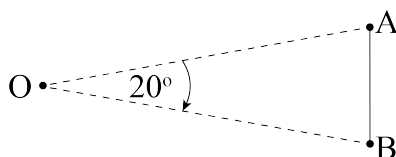

Elle répète ce processus, en faisant tourner la ficelle de 20° dans le sens des aiguilles d'une montre, en faisant un point et en reliant ce point au point précédent par une ligne droite à chaque fois, jusqu'à ce qu'elle ait fait tout le tour du cercle et complété le polygone.

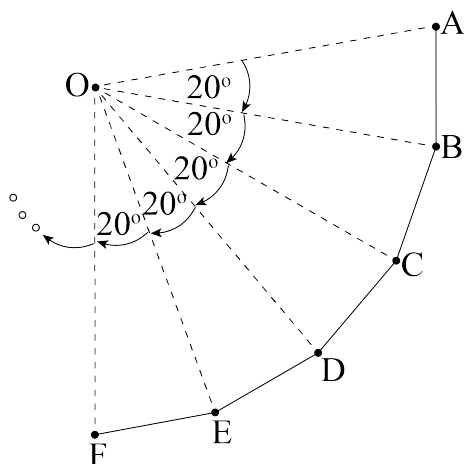

- Une fois complété, combien de côtés le polygone de Priya a-t-il ?
- Quelle est la somme de tous les angles intérieurs du polygone ?

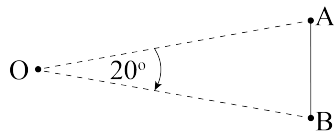

Problem of the Week

Problem C and Solution

One Dot at a Time

Problem

Priya is drawing a polygon on a piece of wood. First she hammers a nail into the piece of wood, calling this point O . Then she attaches one end of a piece of string to the nail, and the other end to a pencil. She pulls the string tight and makes a dot on the wood, calling this point A . Keeping the string tight, she rotates it 20° clockwise and makes another dot, calling this point B . She then connects points A and B with a straight line. She repeats this process, rotating the string 20° clockwise, making a dot, and connecting this point to the previous point with a straight line each time, until she has gone all the way around the circle and completed the polygon.

- How many sides does Priya's completed polygon have?
- What is the sum of all the interior angles in the polygon?

Solution

- Each time the process is repeated, another congruent triangle is created. Each of these triangles has a 20° angle at O , the centre of the circle. Since a complete rotation at the centre is 360° , that means there are $360 \div 20 = 18$ triangles formed. Since each triangle has one edge on the side of the polygon, it follows that the polygon has 18 sides. An 18-sided polygon is called an *octadecagon*, from *octa* meaning 8 and *deca* meaning 10.
- Since the distance between each dot and point O (the nail) is always the same, it follows that the two sides of each congruent triangle that connect to point O are equal. Therefore, the congruent triangles are all isosceles, and the angles that are not at point O are all equal. The angles in a triangle sum to 180° , so after the 20° angle is removed, there is 160° remaining for the other two angles. It follows that each of the other two angles in each triangle measures $160^\circ \div 2 = 80^\circ$. The following diagram illustrates this information for the two adjacent triangles AOB and BOC .

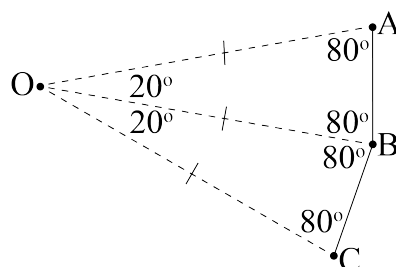



Each interior angle in the polygon is formed by an 80° angle from one triangle and the adjacent 80° angle from the next triangle. It follows that each interior angle measures $80^\circ + 80^\circ = 160^\circ$. Thus, there are 18 interior angles in the octadecagon and each angle measures 160° .

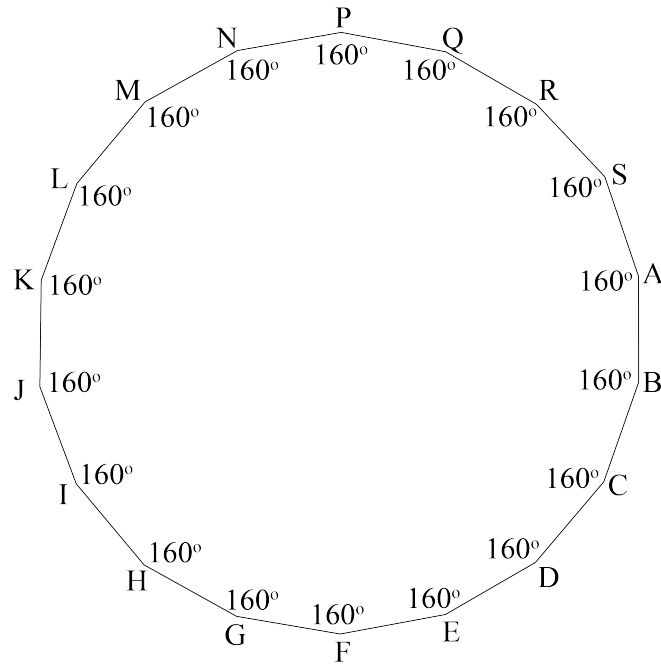

Therefore, the sum of all the interior angles in the octadecagon is $18 \times 160^\circ = 2880^\circ$.



Problème de la semaine

Problème C

Robot peintre

Tesfaye a construit un robot qui peut peindre un chemin en se déplaçant autour d'une feuille de papier. Le robot utilise le système de coordonnées cartésiennes et a l'origine $(0, 0)$ comme point de départ. Les utilisateurs saisissent une liste de points et le robot se déplace d'un point à l'autre de la liste en ligne droite, en peignant le chemin qu'il parcourt. Après avoir atteint le dernier point, il retourne au point $(0, 0)$.

Tesfaye a saisi les coordonnées suivantes dans le robot:

$$(1, 1), (-1, 3), (-3, 3), (-3, 1) \text{ et } (-2, -2).$$

Calcule l'aire de la forme que le robot a peinte.

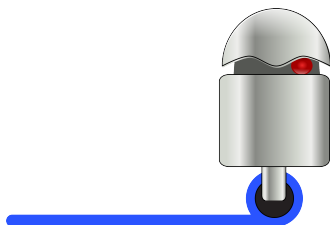

EXTENSION: Quelle est la distance totale parcourue par le robot?

REMARQUE: Les informations suivantes peuvent t'être utiles.

Selon le *théorème de Pythagore*, « Dans un triangle rectangle, le carré de la longueur de l'hypoténuse (le côté opposé à l'angle droit) est égal à la somme des carrés des longueurs des deux autres côtés. »

Dans le triangle rectangle ci-dessous, c est l'hypoténuse, a et b sont les longueurs des deux autres côtés et $c^2 = a^2 + b^2$.

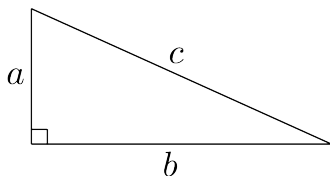

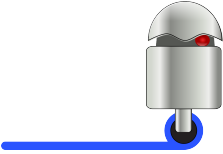

Problem of the Week

Problem C and Solution

Robot Painter

Problem

Tesfaye built a robot that can paint a path as it moves around a piece of paper. The robot uses the Cartesian coordinate system and starts on the point $(0, 0)$. Users enter a list of points and the robot moves from one point to the next point in the list in a straight line, painting the path it travels. After it reaches the last point, it goes back to the point $(0, 0)$.

Tesfaye entered the following coordinates into the robot:

$$(1, 1), (-1, 3), (-3, 3), (-3, 1), \text{ and } (-2, -2).$$

Calculate the area of the shape that the robot painted.

EXTENSION: What is the total distance traveled by the robot?

NOTE: You may find the following useful for the extension:

The *Pythagorean Theorem* states, “In a right-angled triangle, the square of the length of the hypotenuse (the side opposite the right angle) equals the sum of the squares of the lengths of the other two sides.”

In the right-angled triangle shown, c is the hypotenuse, a and b are the lengths of the other two sides, and $c^2 = a^2 + b^2$.

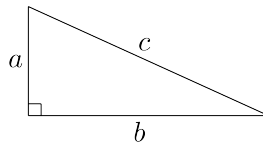

Solution

First we will draw the shape that the robot painted. We label the points $A(0, 0)$, $B(1, 1)$, $C(-1, 3)$, $D(-3, 3)$, $E(-3, 1)$, and $F(-2, -2)$ on the Cartesian plane and connect the points forming polygon $ABCDEF$.

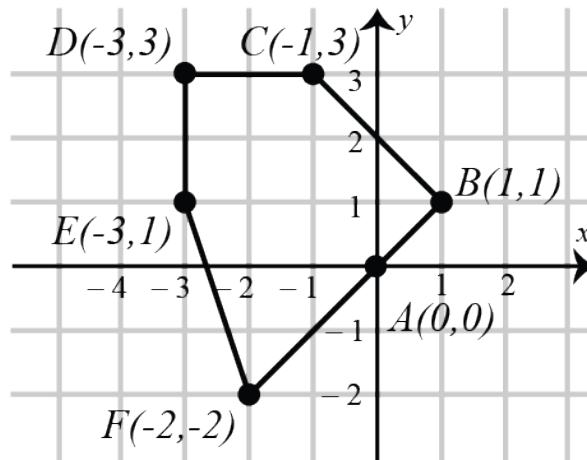



We will make a note here about points F , A , and B . If we move 1 unit right and 1 unit up from $F(-2, -2)$, we get to $(-1, -1)$. If we move 1 unit right and 1 unit up from $(-1, -1)$, we get to $A(0, 0)$. If we move 1 unit right and 1 unit up from $A(0, 0)$, we get to $B(1, 1)$. This illustrates that the points F , A , and B lie on the same line. A detailed discussion of this is provided in high school math courses.

From here, we will present two solutions.

Solution 1

In Solution 1, we will solve the problem by dividing the shape into smaller, more familiar shapes.

There are several ways to do this. One way is to add point $G(-1, 1)$ on line segment EB and notice that segments EB and CG divide the shape into square $CDEG$, $\triangle BCG$, and $\triangle BEF$ as shown.

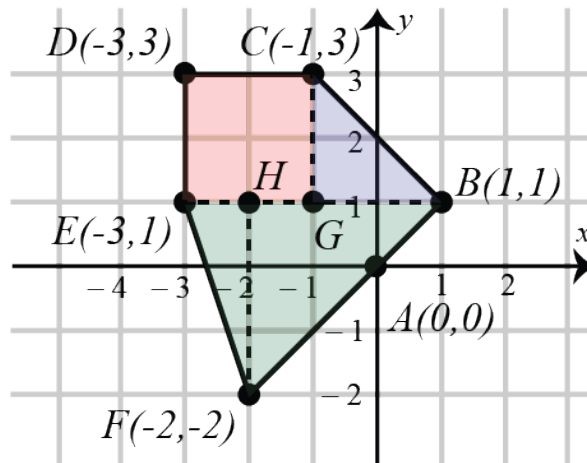

Point $H(-2, 1)$ on EB is also added to form altitude FH of $\triangle BEF$.

We will now calculate the area of each shape and then add these together to find the total area of the shape that the robot painted.

$$\begin{aligned} \text{area of square } CDEG & \\ &= CD \times DE \\ &= 2 \times 2 \\ &= 4 \text{ units}^2 \end{aligned}$$

$$\begin{aligned} \text{area of } \triangle BCG & \\ &= \frac{1}{2} \times BG \times CG \\ &= \frac{1}{2} \times 2 \times 2 \\ &= 2 \text{ units}^2 \end{aligned}$$

$$\begin{aligned} \text{area of } \triangle BEF & \\ &= \frac{1}{2} \times BE \times FH \\ &= \frac{1}{2} \times 4 \times 3 \\ &= 6 \text{ units}^2 \end{aligned}$$

Therefore, the total area of $ABCDEF$ is $4 + 2 + 6 = 12 \text{ units}^2$.

Note that if we had not used the information that the points F , A , and B are on the same line, then we would have had to further break up the region BEF into triangles and trapezoids to calculate the area.



Solution 2

In Solution 2, we will solve the problem by putting the shape inside a rectangle.

One way to do this is to add the points $G(-3, -2)$, $H(1, -2)$, and $I(1, 3)$ and notice that $DGHI$ is a rectangle that contains the shape $ABCDEF$ painted by the robot. Also, the area of rectangle $DGHI$ is covered exactly by shape $ABCDEF$ and three right-angled triangles, $\triangle EFG$, $\triangle BFH$, and $\triangle BCI$.

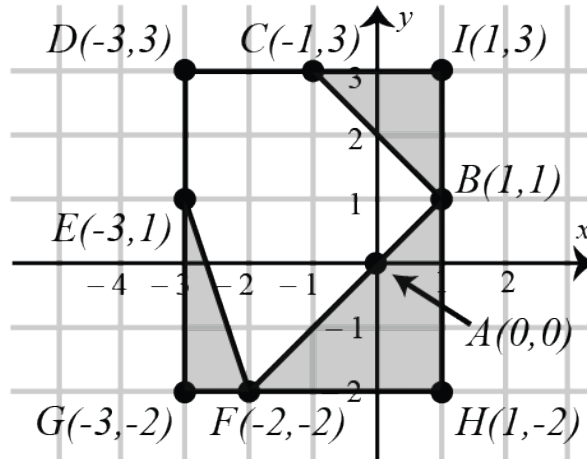

To calculate the area of $ABCDEF$, we will subtract the areas of the three triangles from the area of the rectangle.

area of rectangle $DGHI$ $= GH \times DG$ $= 4 \times 5$ $= 20 \text{ units}^2$	area of $\triangle EFG$ $= \frac{1}{2} \times FG \times EG$ $= \frac{1}{2} \times 1 \times 3$ $= 1.5 \text{ units}^2$	area of $\triangle BFH$ $= \frac{1}{2} \times FH \times BH$ $= \frac{1}{2} \times 3 \times 3$ $= 4.5 \text{ units}^2$	area of $\triangle BCI$ $= \frac{1}{2} \times BI \times CI$ $= \frac{1}{2} \times 2 \times 2$ $= 2 \text{ units}^2$
---	--	--	--

Therefore, the total area of $ABCDEF$ is $20 - 1.5 - 4.5 - 2 = 12 \text{ units}^2$.

Note that if we had not used the information that the points F , A , and B are on the same line, then we would have had to break the region BFH into a triangle and a trapezoid or two triangles and a rectangle to calculate the area.



Solution to the Extension

We will use the diagram from Solution 2 to help us calculate the lengths of the sides of $ABCDEF$.

In Solution 2, we added the points $G(-3, -2)$, $H(1, -2)$, and $I(1, 3)$. Notice that $DGHI$ is a rectangle that contains the shape $ABCDEF$ painted by the robot. Also, the area of rectangle $DGHI$ is covered exactly by shape $ABCDEF$ and three right-angled triangles, $\triangle EFG$, $\triangle BFH$, and $\triangle BCI$.

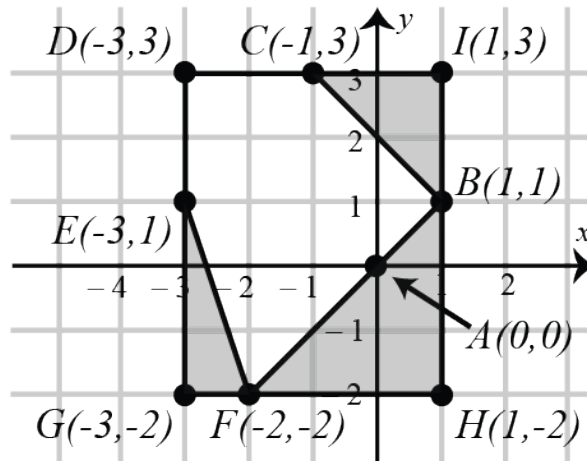

We can determine that $CD = 2$ units and $DE = 2$ units using the diagram or the coordinates of the points. Note that the other three sides of $ABCDEF$ are each the hypotenuse of a right-angled triangle. To find the lengths of these three sides, we can use the Pythagorean Theorem.

$$\begin{aligned} \text{In } \triangle EFG, \\ EF^2 &= EG^2 + FG^2 \\ &= 3^2 + 1^2 \\ &= 9 + 1 \\ &= 10 \end{aligned}$$

$$\text{Thus, } EF = \sqrt{10}.$$

$$\begin{aligned} \text{In } \triangle BFH, \\ BF^2 &= FH^2 + BH^2 \\ &= 3^2 + 3^2 \\ &= 9 + 9 \\ &= 18 \end{aligned}$$

$$\text{Thus, } BF = \sqrt{18}.$$

$$\begin{aligned} \text{In } \triangle BCI, \\ BC^2 &= BI^2 + CI^2 \\ &= 2^2 + 2^2 \\ &= 4 + 4 \\ &= 8 \end{aligned}$$

$$\text{Thus, } BC = \sqrt{8}.$$

The total distance traveled by the robot is the sum of all the side lengths of $ABCDEF$.

$$\begin{aligned} BC + CD + DE + EF + BF &= \sqrt{8} + 2 + 2 + \sqrt{10} + \sqrt{18} \\ &= 4 + \sqrt{8} + \sqrt{10} + \sqrt{18} \\ &\approx 14.2 \text{ units} \end{aligned}$$

Therefore, the total distance traveled by the robot is approximately 14.2 units.



Problème de la semaine

Problème C

Changeons de hauteur!

Le triangle ABC ci-dessous est acutangle. Le point M est choisi sur le segment AB de telle sorte que CM soit une hauteur du triangle ABC . De même, le point N est choisi sur le segment AC de telle sorte que BN soit une hauteur du triangle ABC .

Supposons que $CM = 32$ cm, $AB = 36$ cm et $AC = 40$ cm, quelle est la longueur de la hauteur BN ?

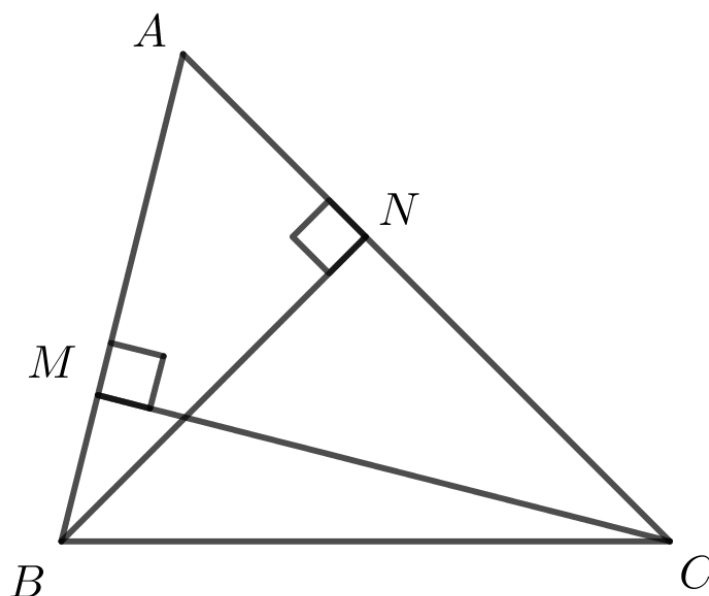

REMARQUE: Une hauteur d'un triangle est un segment de droite issu d'un sommet du triangle qui est perpendiculaire au côté opposé à ce sommet.

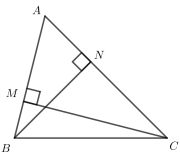

Problem of the Week

Problem C and Solution

Altitude Change

Problem

In acute $\triangle ABC$, two altitudes have been drawn in. Point M lies on AB so that CM is an altitude of $\triangle ABC$, and point N lies on AC so that BN is an altitude of $\triangle ABC$.

Suppose $CM = 32$ cm, $AB = 36$ cm, and $AC = 40$ cm. Determine the length of altitude BN .

Solution

The area of a triangle is determined using the formula

$$\text{area} = \frac{\text{base} \times \text{height}}{2}$$

The height of the triangle is the length of an altitude and the base of the triangle is the length of the side to which a particular altitude is drawn.

Thus,

$$\begin{aligned}\text{Area } \triangle ABC &= \frac{AB \times CM}{2} \\ &= \frac{36 \times 32}{2} \\ &= 576 \text{ cm}^2\end{aligned}$$

Also,

$$\begin{aligned}\text{Area } \triangle ABC &= \frac{AC \times BN}{2} \\ 576 &= \frac{40 \times BN}{2} \\ 1152 &= 40 \times BN \\ BN &= 28.8 \text{ cm}\end{aligned}$$

Therefore, the length of altitude BN is 28.8 cm.

Algèbre (A)





Problème de la semaine

Problème C

Pentagone partitionné

Considérons le pentagone $PQRST$. On nomme les sommets P , Q , R , S et T en partant du coin supérieur gauche du pentagone et en faisant le tour du pentagone dans le sens inverse des aiguilles d'une montre.

Le pentagone a des angles droits à P , Q et R , des angles obtus à S et T , et une aire de 1000 cm^2 .

Le point V est situé à l'intérieur du pentagone de manière que les angles PTV , TVS et VSR soient des angles droits.

Le point U est situé sur TV tel que le triangle STU ait une aire de 210 cm^2 . De plus, $PQ = 50 \text{ cm}$, $SR = 15 \text{ cm}$ et $TU = 30 \text{ cm}$.

Déterminer la longueur de PT .

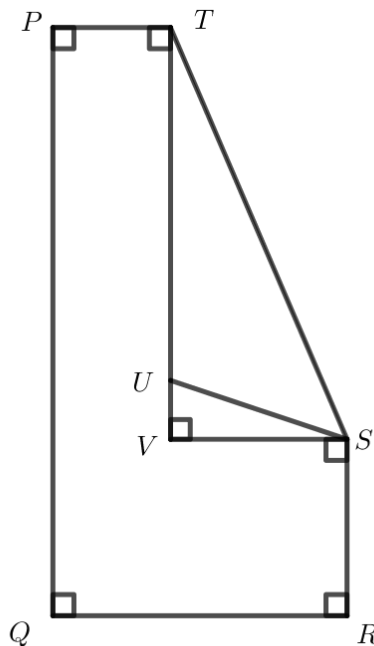

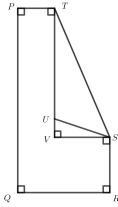

Problem of the Week

Problem C and Solution

Partitioned Pentagon

Problem

Consider pentagon $PQRST$. Starting at P and moving around the pentagon, the vertices are labelled P , Q , R , S , and T , in order. The pentagon has right angles at P , Q , and R , obtuse angles at S and T , and an area of 1000 cm^2 . Point V lies inside the pentagon such that $\angle PTV$, $\angle TVS$, and $\angle VSR$ are right angles. Point U lies on TV such that $\triangle STU$ has an area of 210 cm^2 . Also, it is known that $PQ = 50 \text{ cm}$, $SR = 15 \text{ cm}$, and $TU = 30 \text{ cm}$. Determine the length of PT .

Solution

Extend TV to meet QR at W . We mark this and all of the given information on the diagram.

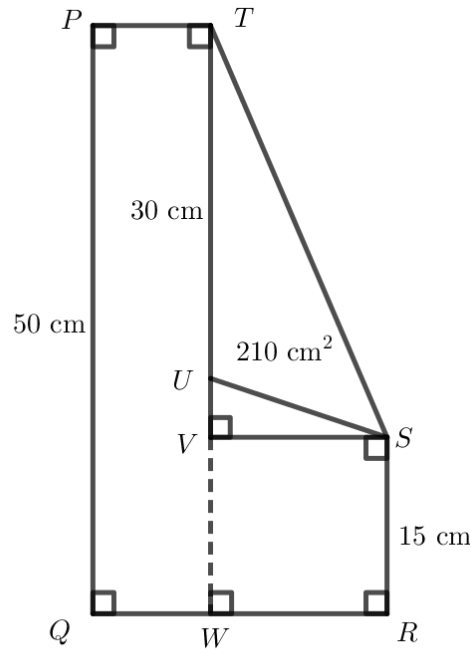

To find the area of a triangle, multiply the length of the base by the height and divide by 2. In $\triangle STU$, the base TU has length 30 cm . The corresponding height of $\triangle STU$ is the perpendicular distance from TU (extended) to vertex S , namely SV .



Since the area of $\triangle STU$ is given to be 210 cm^2 ,

$$210 = \frac{30 \times SV}{2}$$

$$210 = 15 \times SV$$

$$14 = SV$$

We know that $TW = PQ = 50$, $VW = SR = 15$, and $TW = TU + UV + VW$.

It follows that $50 = 30 + UV + 15$ and $UV = 5 \text{ cm}$.

Now we can relate the total area of the pentagon to the areas of the shapes inside.

$$\text{Area } PQRST = \text{Area } PQWT + \text{Area } RSVW + \text{Area } \triangle SUV + \text{Area } \triangle STU$$

$$1000 = PQ \times PT + SV \times SR + \frac{UV \times SV}{2} + 210$$

$$1000 = 50 \times PT + 14 \times 15 + \frac{5 \times 14}{2} + 210$$

$$1000 = 50 \times PT + 210 + 35 + 210$$

$$1000 = 50 \times PT + 455$$

$$1000 - 455 = 50 \times PT$$

$$545 = 50 \times PT$$

$$\frac{545}{50} = PT$$

Therefore, $PT = 10.9 \text{ cm}$.



Problème de la semaine

Problème C

De nombres et de craie

Marta a écrit à la craie une suite de six nombres sur le trottoir à l'extérieur de son immeuble. Après les deux premiers nombres, chaque nombre de la suite est égal à la somme des deux nombres précédents. Le premier nombre de la suite est 112 tandis que le dernier est 2021.

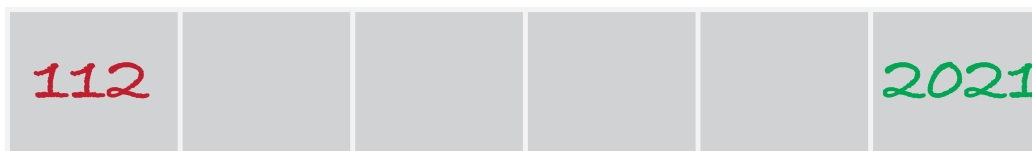

Quels sont les quatre autres nombres de la suite?



112

2021

Problem of the Week

Problem C and Solution

Chalking it Up

Problem

Marta used chalk to create a sequence of six numbers on the sidewalk outside her apartment building. After the first two numbers, each number in the sequence equals the sum of the previous two numbers. Marta started with the number 112 and ended with the number 2021. What are the other four numbers in her sequence?

Solution

Let a represent the second number in the sequence.

Since the third number is the sum of the previous two numbers, the third number is $112 + a$.

Since the fourth number is the sum of the previous two numbers, the fourth number is $a + (112 + a) = 112 + 2a$.

Since the fifth number is the sum of the previous two numbers, the fifth number is $(112 + a) + (112 + 2a) = 224 + 3a$.

Since the sixth number is the sum of the previous two numbers, the sixth number is $(112 + 2a) + (224 + 3a) = 336 + 5a$. But the sixth number in the sequence is 2021. Therefore,

$$336 + 5a = 2021$$

$$336 + 5a - 336 = 2021 - 336$$

$$5a = 1685$$

$$\frac{5a}{5} = \frac{1685}{5}$$

$$a = 337$$

We now know that the second number is 337, so we can determine the remaining numbers in the sequence by substituting into the expressions above or by simply using the rule to generate the remaining numbers. Using the rule, the third number is $112 + 337 = 449$, the fourth number is $337 + 449 = 786$, and the fifth number is $449 + 786 = 1235$. As a check, we can use the rule to determine the sixth number, obtaining $786 + 1235 = 2021$, as required.

Therefore, the other four numbers in Marta's sequence are 337, 449, 786, and 1235.



Problème de la semaine

Problème C

Plus de fleurs s'il vous plaît

Une *vivace* est une plante qui vit pendant plusieurs années. Elle repousse chaque printemps à partir de racines qui sont en état de dormance en automne et en hiver.

Leilani a découvert deux espèces intéressantes de vivaces à la serre du CEMI. Ces espèces sont le point d'étoile bleu et la parabole violette. Après que le point d'étoile bleu soit entré en état de dormance, il repoussera l'année suivante en tant que parabole violette.

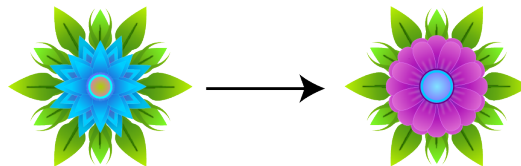

Après que la parabole violette soit entrée en état de dormance, elle repoussera en deux plantes l'année suivante dont une est un point d'étoile bleu tandis que l'autre est une parabole violette.

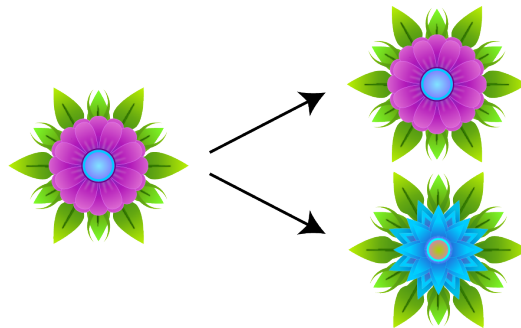

Ce cycle se répète à chaque année.

Un printemps, Leilani a planté deux points d'étoile bleus et trois paraboles violettes dans son jardin. En supposant que les plantes repoussent de la manière décrite ci-dessus et qu'aucune d'elles ne meurt, combien y aura-t-il de points d'étoile bleus et de paraboles violettes dans son jardin après 10 cycles?

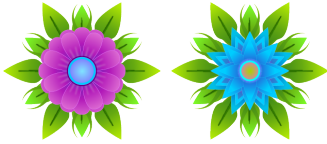

Problem of the Week

Problem C and Solution

More Flowers Please

Problem

A *perennial* is a plant that lives for multiple years. It grows back each spring from roots that go dormant over the autumn and winter. Leilani discovered two interesting species of perennials at the POTW Greenhouse called the Blue Starpoint and the Purple Parabola. After the Blue Starpoint goes dormant, it returns the following year as a Purple Parabola. After the Purple Parabola goes dormant, it returns the following year as two plants; one Blue Starpoint and one Purple Parabola. This cycle happens every year. Leilani planted two Blue Starpoints and three Purple Parabolas in her garden one spring. Assuming the plants behave exactly as described, and all of them continue to survive, how many Blue Starpoints and Purple Parabolas will be in her garden after 10 cycles?

Solution

Leilani started with 2 Blue Starpoints and 3 Purple Parabolas. In one year the 2 Blue Starpoints will become 2 Purple Parabolas. As well, the 3 Purple Parabolas will remain and produce 3 Blue Starpoints. So, after one cycle, there will be 3 Blue Starpoints and $2 + 3 = 5$ Purple Parabolas.

Proceeding from year one to year two, the 3 Blue Starpoints will become 3 Purple Parabolas. As well, the 5 Purple Parabolas will remain and produce 5 Blue Starpoints. So, after two cycles, there will be 5 Blue Starpoints and $3 + 5 = 8$ Purple Parabolas.

At this point we can make an observation. The number of Blue Starpoints in a given year equals the number of Purple Parabolas in the previous year. Also, the number of Purple Parabolas in a given year equals the sum of the Blue Starpoints and Purple Parabolas in the previous year. We can use this observation to make a table for the remaining years.

Year Number	Number of Blue Starpoints	Number of Purple Parabolas
0	2	3
1	3	5
2	5	8
3	8	13
4	13	21
5	21	34
6	34	55
7	55	89
8	89	144
9	144	233
10	233	377

After ten cycles, there will be 233 Blue Starpoints and 377 Purple Parabolas, for a total of $233 + 377 = 610$ plants in Leilani's garden. Hopefully she has a big garden!



EXTENSION:

This problem was inspired by a past [Beaver Computing Challenge \(BCC\)](#) problem.

The number of a particular flower type in a specific year is dependent on the number of flowers of each of the types from the previous year. This is an example of a *recursion*.

A famous example of a recursion is known as the *Fibonacci Sequence*. The first two numbers (or *terms*) in the sequence of numbers are defined. They are both 1. Each remaining term in the sequence is equal to the sum of the two previous terms.

So, the third term is equal to the sum of the first and second terms, and is therefore $1 + 1 = 2$.

The fourth term is equal to the sum of the second and third terms, and is therefore $1 + 2 = 3$.

The fifth term is equal to the sum of the third and fourth terms, and is therefore $2 + 3 = 5$.

We can continue generating more terms in the sequence in this manner.

The first 15 Fibonacci numbers are

1, 1, 2, 3, 5, 8, 13, 21, 34, 55, 89, 144, 233, 377, and 610.

In our problem, the number of Purple Parabolas in a given year equals the sum of the number of Blue Starpoints and Purple Parabolas in the previous year. If we had started with only 1 Blue Starpoint and 0 Purple Parabolas, the number of Purple Parabolas after each cycle would match the terms in the Fibonacci sequence. Try it out!



Problème de la semaine

Problème C

En moyenne

Quatre nombres entiers positifs différents ont une moyenne de 100. Si la différence positive entre le plus grand nombre entier et le plus petit nombre entier est aussi grande que possible, détermine la moyenne des deux autres nombres entiers.

PROBLÈME SUPPLÉMENTAIRE: Peux-tu résoudre le rébus ci-dessous?

LÉGÈREMENT
MOYENNE



SLIGHTLY AVERAGE

Problem of the Week

Problem C and Solution

Average Out

Problem

Four different positive integers have a mean (average) of 100. If the positive difference between the smallest and largest of these integers is as large as possible, determine the average of the other two integers.

EXTRA PROBLEM: Can you interpret the picture puzzle above?

Solution

Let a , b , c , and d represent four distinct positive integers such that $a < b < c < d$.

Since the average of the four positive integers is 100, their sum can be determined by multiplying their average by 4. Therefore, the sum of the numbers is $4 \times 100 = 400$. That is, $a + b + c + d = 400$.

For the difference between the largest integer and the smallest integer to be as large as possible, we want the smallest integer, a , to be as small as possible. The smallest positive integer is 1, so $a = 1$.

Since the sum of the four positive integers is 400 and the smallest integer, a , is 1, the sum of the remaining three integers is $b + c + d = 400 - 1 = 399$.

For the difference between the largest integer and the smallest integer to be as large as possible, we also want the largest integer, d , to be as large as possible. For d to be as large as possible, b and c must be as small as possible. The two positive integers, b and c , must be different and cannot equal 1, since $a = 1$. Therefore, $b = 2$ and $c = 3$, the smallest two remaining distinct positive integers. It follows that d , the largest of the four positive integers, is $399 - 2 - 3 = 394$. (This was not required but has been provided for completeness.)

The average of the middle two positive integers, b and c , is $\frac{2+3}{2} = \frac{5}{2} = 2.5$.

EXTENSION:

How would your answer change if it was also required that the average of b and c was an integer greater than or equal to 3?

EXTRA PROBLEM ANSWER: Slightly above average.



Problème de la semaine

Problème C

Bonbons surprises!

Ru a 100 bonbons qu'elle place dans des petites boîtes pour un jeu lors d'une fête. Elle a décidé que chaque boîte doit contenir au moins un bonbon et que deux boîtes ne peuvent pas contenir le même nombre de bonbons. De plus, aucune boîte ne peut être placée à l'intérieur d'une autre boîte.

Détermine le nombre maximum de boîtes qu'elle peut utiliser pour ses bonbons.

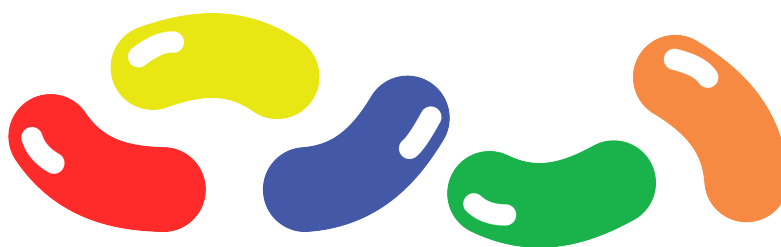



Problem of the Week

Problem C and Solution

Jellybean Surprise

Problem

Ru has 100 jellybeans that she is placing in small boxes for a party game. She has decided that each box must contain at least one jellybean and no two boxes can contain the same number of jellybeans. As well, no box can go inside any other box.

Determine the maximum number of boxes Ru can use for her jellybeans.

Solution

In order to maximize the number of boxes, each box must contain the smallest number of jellybeans possible. However, no two boxes can contain the same number of jellybeans. The simplest way to approach this problem is to put one jellybean in the first box and then let the number of jellybeans in each box after that be one more than the number of jellybeans in the box before it, until all 100 jellybeans are in boxes.

We will put 1 jellybean in the first box, 2 jellybeans in the second box, 3 jellybeans in the third box, and so on. After filling 12 boxes this way, we have used $1 + 2 + 3 + 4 + 5 + 6 + 7 + 8 + 9 + 10 + 11 + 12 = 78$ jellybeans. After putting 13 jellybeans in the thirteenth box, we have used $78 + 13 = 91$ jellybeans. There are 9 jellybeans left, but we already have a box containing 9 jellybeans. The remaining 9 jellybeans must therefore be distributed among the existing boxes while maintaining the condition that no two boxes contain the same number of jellybeans.

One way to do this is to put the 9 jellybeans in the last box which already contains 13 jellybeans. This would mean that the final box would contain $13 + 9 = 22$ jellybeans. Another solution is to increase the number of jellybeans in each of the final nine boxes by one jellybean each. This solution is summarized in the following table.

Box Number	1	2	3	4	5	6	7	8	9	10	11	12	13
Number of Jellybeans	1	2	3	4	6	7	8	9	10	11	12	13	14

Either way, the maximum number of boxes required is 13.

If you had 14 boxes, with the first box containing 1 jellybean and each box after that containing one more jellybean than the box before, you would need $1 + 2 + 3 + \dots + 13 + 14 = 105$ jellybeans, which is more than the number of jellybeans Ru has.



Problème de la semaine

Problème C

Compter des pièces

Inaaya a un bocal de pièces de monnaie contenant uniquement des pièces de 5 cents, de 10 cents et de 25 cents. Remarque qu'un dollar vaut 100 cents.

Le rapport du nombre de pièces de 25 cents au nombre de pièces de 10 cents au nombre de pièces de 5 cents est de $9 : 3 : 1$. Les pièces de monnaie dans le bocal ont une valeur totale de 18,20 \$. Combien y a-t-il de pièces dans le bocal d'Inaaya?





Problem of the Week

Problem C and Solution

Counting Coins

Problem

Inaaya has a jar of coins containing only nickels, dimes, and quarters. A nickel is worth 5 cents, a dime is worth 10 cents, a quarter is worth 25 cents, and a dollar is worth 100 cents.

The ratio of the number of quarters to the number of dimes to the number of nickels in the jar is $9 : 3 : 1$. The total value of all the coins in the jar is \$18.20. How many coins does Inaaya have in her jar?

Solution

Solution 1

Suppose the jar contained 1 nickel. Then, using the ratio $9 : 3 : 1$, the jar would contain 9 quarters, 3 dimes, and 1 nickel, which is 13 coins in total. The value of the 13 coins would be $25 \times 9 + 10 \times 3 + 5 \times 1 = 260$ cents or \$2.60.

Since the coins in the jar are in the ratio $9 : 3 : 1$, then we can group the coins into sets of 9 quarters, 3 dimes, and 1 nickel, with each set containing 13 coins and having a value of \$2.60.

Since the total value of the coins in the jar is \$18.20 and $\frac{\$18.20}{\$2.60} = 7$, then there are 7 of these sets of coins. Since each set has 13 coins, then there is a total of $7 \times 13 = 91$ coins in the jar.

Solution 2

This solution uses algebra which may or may not be too advanced for the solver.

Suppose there are n nickels in the jar. Then, using the ratio $9 : 3 : 1$, the jar would contain $9n$ quarters, $3n$ dimes, and n nickels, which is $13n$ coins in total.

The value of the coins would be

$$25 \times 9n + 10 \times 3n + 5 \times n = 225n + 30n + 5n = 260n \text{ cents}$$

The total value of the coins in the jar is \$18.20, or 1820 cents. Therefore,

$$\begin{aligned} 260n &= 1820 \\ \frac{260n}{260} &= \frac{1820}{260} \\ n &= 7 \end{aligned}$$

Since there are $13n$ coins in the jar and $n = 7$, there is a total of $13 \times 7 = 91$ coins in the jar.



Solution 3

In this solution, we look at the possibilities for the number of nickels, and systematically increase the number of nickels until the conditions in the problem are satisfied with that number of nickels. This solution is presented in a table.

Number of nickels	Number of quarters	Number of dimes	Number of coins	Total value of coins (in cents)
1	$9 \times 1 = 9$	$3 \times 1 = 3$	$1 + 9 + 3 = 13$	$1 \times 5 + 9 \times 25 + 3 \times 10 = 260$
2	$9 \times 2 = 18$	$3 \times 2 = 6$	$2 + 18 + 6 = 26$	$2 \times 5 + 18 \times 25 + 6 \times 10 = 520$
3	$9 \times 3 = 27$	$3 \times 3 = 9$	$3 + 27 + 9 = 39$	$3 \times 5 + 27 \times 25 + 9 \times 10 = 780$
4	$9 \times 4 = 36$	$3 \times 4 = 12$	$4 + 36 + 12 = 52$	$4 \times 5 + 36 \times 25 + 12 \times 10 = 1040$
5	$9 \times 5 = 45$	$3 \times 5 = 15$	$5 + 45 + 15 = 65$	$5 \times 5 + 45 \times 25 + 15 \times 10 = 1300$
6	$9 \times 6 = 54$	$3 \times 6 = 18$	$6 + 54 + 18 = 78$	$6 \times 5 + 54 \times 25 + 18 \times 10 = 1560$
7	$9 \times 7 = 63$	$3 \times 7 = 21$	$7 + 63 + 21 = 91$	$7 \times 5 + 63 \times 25 + 21 \times 10 = 1820$

From the table, we see that there is a total of 91 coins in the jar.



Problème de la semaine

Problème C

Menu du jour

Jessica et Callista vont au restaurant-minute du coin. Elles veulent toutes les deux acheter le menu du jour. Jessica a $\frac{3}{4}$ de l'argent qu'il lui faut pour acheter le menu du jour tandis que Callista a la moitié de l'argent qu'il lui faut pour l'acheter. Si le menu du jour coûtait 3 \$ de moins, alors elles auraient exactement assez d'argent pour acheter deux menus du jour si elles mettaient leur argent en commun.

Quel est le prix initial du menu du jour?

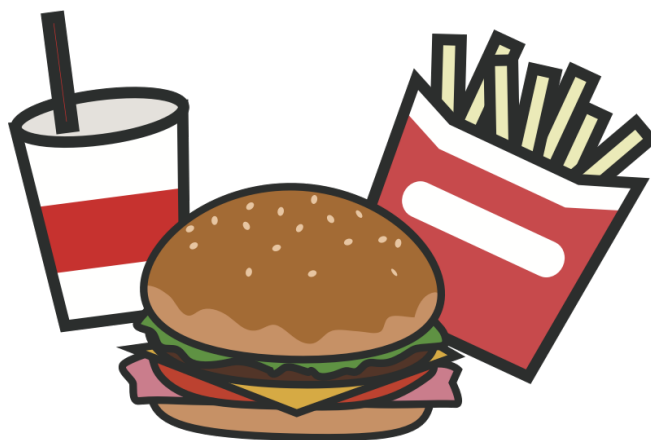

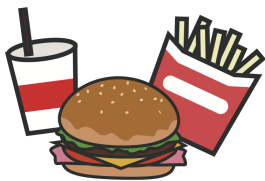

Problem of the Week

Problem C and Solution

Meal Deal

Problem

Jessica and Callista go to the local burger joint. They both want to buy the meal deal. Jessica has $\frac{3}{4}$ of the money needed to buy the meal deal and Callista has half of the money needed to buy the meal deal. If the meal deal was \$3 cheaper, then together they would have exactly enough money to buy two of the meal deals.

What is the original price of the meal deal?

Solution

Solution 1:

Suppose that the cost of the meal deal, in dollars, is C . Then Jessica has $\frac{3}{4}C$ and Callista has $\frac{1}{2}C$. Combining their money, together Jessica and Callista have

$$\frac{3}{4}C + \frac{1}{2}C = \frac{3}{4}C + \frac{2}{4}C = \frac{5}{4}C$$

If the meal deal was \$3 cheaper, then the cost to buy one meal deal would be $C - 3$. If the cost of one meal deal was $C - 3$, then the cost to buy two meal deals at this price would be $2(C - 3) = (C - 3) + (C - 3) = 2C - 6$.

Combined, Jessica and Callista would have enough money to buy exactly two meal deals at this reduced price. Thus, $2C - 6 = \frac{5}{4}C$.

Solving for C ,

$$\begin{aligned}2C - 6 &= \frac{5}{4}C \\2C - \frac{5}{4}C &= 6 \\ \frac{8}{4}C - \frac{5}{4}C &= 6 \\ \frac{3}{4}C &= 6 \\ 3C &= 24 \\ C &= 8\end{aligned}$$

Therefore, the original price of the meal deal is \$8.

**Solution 2:**

Since the new price of the meal deal is \$3 cheaper than the original price, then the original price must be more than \$3. We will use systematic trial and error to figure out the original price.

Suppose the original price of the meal deal was \$6. Then the reduced price would be \$3. Also, Jessica has $\frac{3}{4} \times \$6 = \4.50 and Callista has $\frac{1}{2} \times \$6 = \3 , and in total they have $\$4.50 + \$3 = \$7.50$. With \$7.50, they could buy exactly $7.50 \div 3 = 2.5$ meal deals at a price of \$3 each.

Suppose the original price of the meal deal was \$12. Then the reduced price would be \$9. Also, Jessica has $\frac{3}{4} \times \$12 = \9 and Callista has $\frac{1}{2} \times \$12 = \6 , and in total they have $\$9 + \$6 = \$15$. With \$15, they could buy $15 \div 9 \approx 1.67$ meal deals at a price of \$9 each.

We can see that the original price of the meal deal lies somewhere between \$6 and \$12.

Let's suppose the original price of the meal deal was \$8. Then the reduced price would be \$5. Also, Jessica has $\frac{3}{4} \times \$8 = \6 and Callista has $\frac{1}{2} \times \$8 = \4 , and in total they have $\$6 + \$4 = \$10$. With \$10, they could buy exactly $10 \div 5 = 2$ meal deals at a price of \$5 each.

Thus, we can see that the original price of the meal deal is \$8.

Gestion des données (D)





Problème de la semaine

Problème C

Somme de dés

Ahmik a créé un jeu pour le carnaval de son école. Dans ce jeu, les joueurs lancent deux dés et déterminent la somme des deux nombres sur les faces supérieures. Si cette somme est un carré parfait ou un nombre premier, ils gagnent un prix. Pour rendre les choses plus intéressantes, Ahmik a fabriqué les deux dés à l'aide d'une imprimante 3D afin que les nombres 1, 2, 3, 5, 7 et 9 paraissent sur les faces des dés. L'un des dés est violet tandis que l'autre est vert. Quelle est la probabilité pour qu'un joueur gagne un prix après avoir lancé les dés une seule fois?

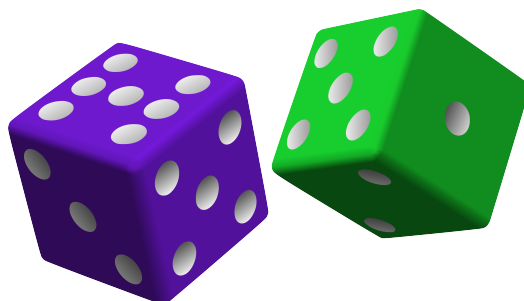

NOTE:

Le carré d'un entier est un *carré parfait*. Par exemple, 25 est un carré parfait puisqu'il peut être exprimé sous la forme 5^2 ou 5×5 .

Un *nombre premier* est un entier supérieur à 1 qui admet exactement deux diviseurs positifs distincts, soit 1 et lui-même. Par exemple, 17 est un nombre premier car ses seuls diviseurs positifs sont 1 et 17.

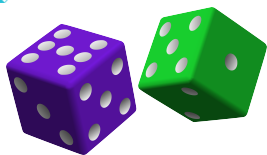

Problem of the Week

Problem C and Solution

Just Sum Dice

Problem

Ahmik created a game for his school's carnival where players roll two dice and find the sum of the two numbers on the top faces. If this sum is a perfect square or a prime number, they win a prize. To make it more interesting, Ahmik made the two dice using a 3D printer so that they each have the numbers 1, 2, 3, 5, 7, and 9 on their faces. One of the dice is purple and the other is green.

What is the probability that a player will win a prize after rolling the dice once?

NOTE:

A square of any integer is called a *perfect square*. The number 25 is a perfect square since it can be expressed as 5^2 or 5×5 .

A *prime number* is an integer greater than 1 that has only two positive divisors; 1 and itself. The number 17 is prime because its only positive divisors are 1 and 17.

Solution

To solve this problem, we will create a table where the columns show the possible rolls of the green die, the rows show the possible rolls of the purple die, and each cell in the body of the table gives the sum for the corresponding pair of rolls.

		Green Die					
		1	2	3	5	7	9
Purple Die	1	2	3	4	6	8	10
	2	3	4	5	7	9	11
	3	4	5	6	8	10	12
	5	6	7	8	10	12	14
	7	8	9	10	12	14	16
	9	10	11	12	14	16	18

From the table, we see that there are 36 possible outcomes. We also see that the perfect squares 4, 9, and 16 appear as sums in the table seven times in total.

The smallest sum in the table is 2, and the largest sum in the table is 18. The prime numbers in this range appearing as sums in the table are 2, 3, 5, 7, and 11. These sums appear nine times in total.

Thus, there are 7 sums that are perfect squares and 9 sums that are prime numbers in the table. Since a number cannot be both a prime number and a perfect square, we can conclude that there are $7 + 9 = 16$ sums that are prime numbers or perfect squares.

To determine the probability of a specific outcome, we divide the number of times the specific outcome occurs by the total number of possible outcomes. Thus, the probability of a player rolling a sum that is either a prime number or a perfect square is $16 \div 36 = \frac{4}{9} \approx 44\%$.

Therefore, a player has approximately a 44% chance of winning a prize after rolling the dice once.

EXTENSION: A game is considered fair if the chance of winning is 50%. How could you change the rules of this game to make it fair?



Problème de la semaine

Problème C

Chaque chose à sa place 1

- (a) Un diagramme de Venn comporte deux cercles, soit les cercles A et B. Chaque cercle contient des nombres entiers qui répondent aux critères suivants.

A: Inférieur à $-\frac{7}{61}$
B: Supérieur à $-\frac{61}{4}$

La région au milieu, créée par le chevauchement des deux cercles, contient des entiers qui sont compris à la fois dans A et B tandis que la région à l'extérieur des deux cercles contient des entiers qui ne sont ni dans A ni dans B.

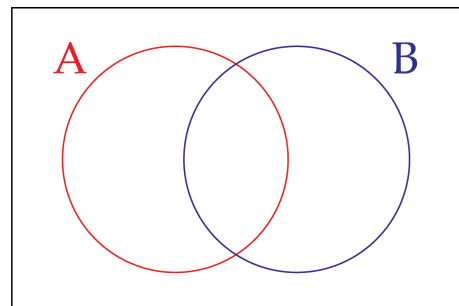

Au total, ce diagramme de Venn comporte quatre régions. Place des entiers dans autant de régions que tu le peux. Est-il possible de trouver un entier pour chaque région?

- (b) Un diagramme de Venn comporte trois cercles, soit les cercles A, B et C. Chaque cercle contient des couples d'entiers qui répondent aux critères suivants.

A: Leur somme est négative
B: Leur produit est négatif
C: Leur différence est paire

Au total, ce diagramme de Venn comporte huit régions. Place des couples d'entiers dans autant de régions que tu le peux. Est-il possible de trouver un couple d'entiers pour chaque région?

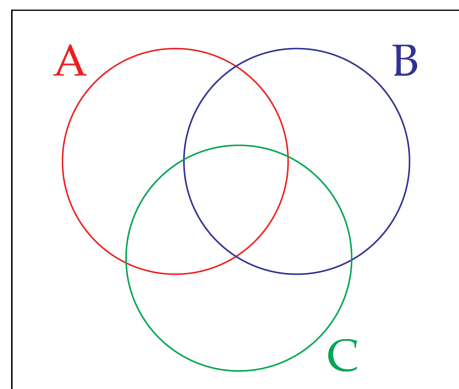



Problem of the Week

Problem C and Solution

Everything in its Place 1

Problem

- (a) A Venn diagram has two circles, labelled A and B. Each circle contains integers that satisfy the following criteria.

A: Less than $-\frac{7}{6}$

B: Greater than $-\frac{1}{4}$

The overlapping region in the middle contains integers that are in both A and B, and the region outside both circles contains integers that are neither in A nor B. In total this Venn diagram has four regions. Place integers in as many of the regions as you can. Is it possible to find an integer for each region?

- (b) A Venn diagram has three circles, labelled A, B, and C. Each circle contains pairs of integers that satisfy the following criteria.

A: Their sum is negative

B: Their product is negative

C: Their difference is even

In total this Venn diagram has eight regions. Place pairs of integers in as many of the regions as you can. Is it possible to find a pair of integers for each region?

Solution

- (a) We have marked the four regions W, X, Y, and Z.

We plot the given fractions on a number line as a reference:

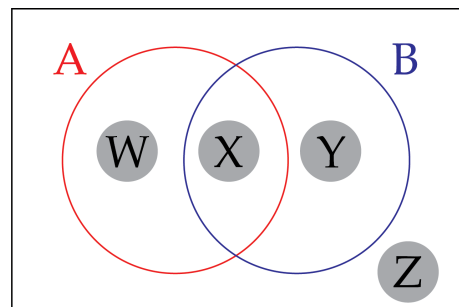
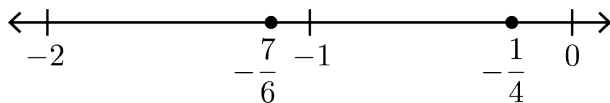

- Any integer in region W must be less than $-\frac{7}{6}$ and *not* greater than $-\frac{1}{4}$. This means the integer must be less than $-\frac{7}{6}$ and less than or equal to $-\frac{1}{4}$. Any integer less than or equal to -2 will satisfy this. Some examples are -2 , -3 , and -10 .
- Any integer in region X must be less than $-\frac{7}{6}$ and greater than $-\frac{1}{4}$. It is not possible to find such an integer so this region must remain empty.
- Any integer in region Y must be greater than $-\frac{1}{4}$ and *not* less than $-\frac{7}{6}$. This means the integer must be greater than $-\frac{1}{4}$ and greater than or equal to $-\frac{7}{6}$. Any integer greater than or equal to 0 will satisfy this. Some examples are 0 , 1 , and 30 .
- Any integer in region Z must be *not* less than $-\frac{7}{6}$ and *not* greater than $-\frac{1}{4}$. This means the integer must be greater than or equal to $-\frac{7}{6}$ and less than or equal to $-\frac{1}{4}$. The only integer that satisfies this is -1 .



- (b) We have marked the eight regions S, T, U, V, W, X, Y, and Z. It is helpful if we first think about the pairs of integers that each circle could contain. Two integers have a negative sum if they are both negative, or they have different signs and the negative number is larger in magnitude than the positive number. Two integers have a negative product if they have different signs. Two integers have an even difference if they are both even or both odd, regardless of their signs, and regardless of which number is being subtracted from the other.

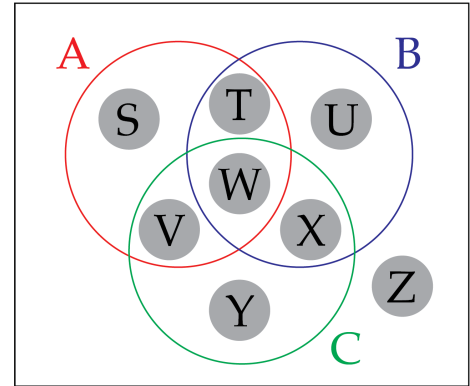

- Any pair of integers in region S must have a negative sum, a positive product, and an odd difference. This means they must both be negative, and one must be even and the other must be odd. One example is -5 and -6 , because $(-5) + (-6) = -11 < 0$, $(-5) \times (-6) = 30 > 0$, and $(-5) - (-6) = 1$, which is odd.
- Any pair of integers in region T must have a negative sum, a negative product, and an odd difference. This means they must have different signs, and the negative number must be larger in magnitude than the positive number. Also one number must be even and the other must be odd. One example is 3 and -8 , because $3 + (-8) = -5 < 0$, $3 \times (-8) = -24 < 0$, and $3 - (-8) = 11$, which is odd.
- Any pair of integers in region U must have a positive sum, a negative product, and an odd difference. This means they must have different signs, and the positive number must be larger in magnitude than the negative number. Also one number must be even and the other must be odd. One example is 8 and -3 , because $8 + (-3) = 5 > 0$, $8 \times (-3) = -24 < 0$, and $8 - (-3) = 11$, which is odd.
- Any pair of integers in region V must have a negative sum, a positive product, and an even difference. This means they must both be negative, and they must be either both even or both odd. One example is -4 and -6 , because $(-4) + (-6) = -10 < 0$, $(-4) \times (-6) = 24 > 0$, and $(-4) - (-6) = 2$, which is even.
- Any pair of integers in region W must have a negative sum, a negative product, and an even difference. This means they must have different signs, and the negative number must be larger in magnitude than the positive number. Also they must be either both even or both odd. One example is 2 and -8 , because $2 + (-8) = -6 < 0$, $2 \times (-8) = -16 < 0$, and $2 - (-8) = 10$, which is even.
- Any pair of integers in region X must have a positive sum, a negative product, and an even difference. This means they must have different signs, and the positive number must be larger in magnitude than the negative number. Also they must be either both even or both odd. One example is 8 and -2 , because $8 + (-2) = 6 > 0$, $8 \times (-2) = -16 < 0$, and $8 - (-2) = 10$, which is even.
- Any pair of integers in region Y must have a positive sum, a positive product, and an even difference. This means they must both be positive, and either both even or both odd. One example is 5 and 3 , because $5 + 3 = 8 > 0$, $5 \times 3 = 15 > 0$, and $5 - 3 = 2$, which is even.
- Any pair of integers in region Z must have a positive sum, a positive product, and an odd difference. This means they must both be positive, and one must be even and the other must be odd. One example is 5 and 4 , because $5 + 4 = 9 > 0$, $5 \times 4 = 20 > 0$, and $5 - 4 = 1$, which is odd.

Raisonnement informatiques (C)





Problème de la semaine

Problème C

Un trio solo

Sandip écrit un programme informatique qui reproduira des sons de piano, de violoncelle (soit **cello**) et de violon. Son programme comprend des commandes qui démarrent (soit **start**) ou qui arrêtent (soit **stop**) le son de chaque instrument, ainsi qu'une commande pour attendre (soit **wait**) une période de temps donnée pendant que les instruments jouent. On voit son programme informatique ci-dessous.

```
REPEAT 10 times:  
  start(piano)  
  wait(3sec)  
  start(cello)  
  start(violin)  
  wait(5sec)  
  stop(violin)  
  wait(2sec)  
  start(violin)  
  stop(piano)  
  wait(2sec)  
  stop(violin)  
  stop(cello)
```

- (a) Combien de temps faut-il pour que le programme s'exécute complètement du début jusqu'à la fin? (Supposons que l'ordinateur de Sandip est si rapide que le temps de l'exécution des commandes elles-mêmes est négligeable.)
- (b) Quels instruments jouent exactement 33 secondes après qu'on ait lancé le programme informatique?





Problem of the Week

Problem C and Solution

A Solo Trio

Problem

Sandip is writing a computer program that will play sounds that imitate a piano, cello, and violin. He has commands that start or stop the sound of each instrument, as well as a command to wait for a given period of time while the instruments play. He uses these commands to write the following program.

```
REPEAT 10 times:  
  start(piano)  
  wait(3sec)  
  start(cello)  
  start(violin)  
  wait(5sec)  
  stop(violin)  
  wait(2sec)  
  start(violin)  
  stop(piano)  
  wait(2sec)  
  stop(violin)  
  stop(cello)
```

- How long does it take for the program to execute completely from start to finish? Assume that Sandip's computer is so fast that it doesn't take any time at all to execute each command.
- Which instruments are playing exactly 33 seconds after the program starts running?

Solution

- First we will calculate how many seconds it takes to go through the repeat block once. Since $3 + 5 + 2 + 2 = 12$, it takes 12 seconds to go through the repeat block once. Since we go through the repeat block 10 times, it takes $12 \times 10 = 120$ seconds (or 2 minutes) to execute the program completely from start to finish.
- There are two solutions for this part.

Solution 1:

We know from part (a) that it takes 12 seconds to execute the repeat block once. Since $12 \times 2 + 9 = 33$, that means after 33 seconds, the program will have executed the repeat block twice, and be 9 seconds into its third pass.



If we look at the code in the repeat block, we can see that all three instruments are started in the beginning and stopped at the end. This tells us we don't need to consider the first two times through the repeat block and can focus only on which instruments are playing 9 seconds into the repeat block. We will walk through the code until we reach 9 seconds.

```
start(piano)
wait(3sec)
```

Thus, after 3 seconds, only the piano is playing. We will look through the next part of the code.

```
start(cello)
start(violin)
wait(5sec)
```

After $3 + 5 = 8$ seconds, the piano, cello, and violin are all playing. We will look through the next part of the code.

```
stop(violin)
wait(2sec)
```

The violin stops, and then the program waits for 2 seconds. Since $8 + 1 = 9$ seconds, that means 9 seconds into the repeat block, the program is waiting. At this point, only the piano and cello are playing.

Therefore, 33 seconds after the program starts running, the piano and cello are the only instruments playing.

Solution 2:

We can walk through the first 33 seconds of the code and record which instruments are playing at each second. We will let "P" represent piano, "C" represent cello, and "V" represent violin and summarize our findings in a table.

Seconds Elapsed	Instruments Playing
1	P
2	P
3	P
4	P C V
5	P C V
6	P C V
7	P C V
8	P C V
9	P C
10	P C
11	C V
12	C V

Seconds Elapsed	Instruments Playing
13	P
14	P
15	P
16	P C V
17	P C V
18	P C V
19	P C V
20	P C V
21	P C
22	P C
23	C V
24	C V

Seconds Elapsed	Instruments Playing
25	P
26	P
27	P
28	P C V
29	P C V
30	P C V
31	P C V
32	P C V
33	P C
34	P C
35	C V
36	C V

Looking at the table, we can see that 33 seconds after the program starts running, the piano and cello are the only instruments playing.



Problème de la semaine

Problème C

Plus de fleurs s'il vous plaît

Une *vivace* est une plante qui vit pendant plusieurs années. Elle repousse chaque printemps à partir de racines qui sont en état de dormance en automne et en hiver.

Leilani a découvert deux espèces intéressantes de vivaces à la serre du CEMI. Ces espèces sont le point d'étoile bleu et la parabole violette. Après que le point d'étoile bleu soit entré en état de dormance, il repoussera l'année suivante en tant que parabole violette.

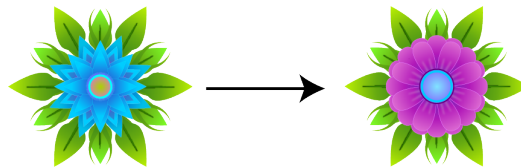

Après que la parabole violette soit entrée en état de dormance, elle repoussera en deux plantes l'année suivante dont une est un point d'étoile bleu tandis que l'autre est une parabole violette.

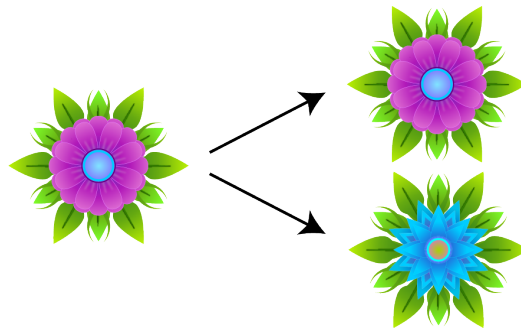

Ce cycle se répète à chaque année.

Un printemps, Leilani a planté deux points d'étoile bleus et trois paraboles violettes dans son jardin. En supposant que les plantes repoussent de la manière décrite ci-dessus et qu'aucune d'elles ne meurt, combien y aura-t-il de points d'étoile bleus et de paraboles violettes dans son jardin après 10 cycles?

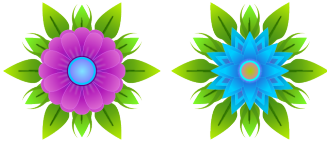

Problem of the Week

Problem C and Solution

More Flowers Please

Problem

A *perennial* is a plant that lives for multiple years. It grows back each spring from roots that go dormant over the autumn and winter. Leilani discovered two interesting species of perennials at the POTW Greenhouse called the Blue Starpoint and the Purple Parabola. After the Blue Starpoint goes dormant, it returns the following year as a Purple Parabola. After the Purple Parabola goes dormant, it returns the following year as two plants; one Blue Starpoint and one Purple Parabola. This cycle happens every year. Leilani planted two Blue Starpoints and three Purple Parabolas in her garden one spring. Assuming the plants behave exactly as described, and all of them continue to survive, how many Blue Starpoints and Purple Parabolas will be in her garden after 10 cycles?

Solution

Leilani started with 2 Blue Starpoints and 3 Purple Parabolas. In one year the 2 Blue Starpoints will become 2 Purple Parabolas. As well, the 3 Purple Parabolas will remain and produce 3 Blue Starpoints. So, after one cycle, there will be 3 Blue Starpoints and $2 + 3 = 5$ Purple Parabolas.

Proceeding from year one to year two, the 3 Blue Starpoints will become 3 Purple Parabolas. As well, the 5 Purple Parabolas will remain and produce 5 Blue Starpoints. So, after two cycles, there will be 5 Blue Starpoints and $3 + 5 = 8$ Purple Parabolas.

At this point we can make an observation. The number of Blue Starpoints in a given year equals the number of Purple Parabolas in the previous year. Also, the number of Purple Parabolas in a given year equals the sum of the Blue Starpoints and Purple Parabolas in the previous year. We can use this observation to make a table for the remaining years.

Year Number	Number of Blue Starpoints	Number of Purple Parabolas
0	2	3
1	3	5
2	5	8
3	8	13
4	13	21
5	21	34
6	34	55
7	55	89
8	89	144
9	144	233
10	233	377

After ten cycles, there will be 233 Blue Starpoints and 377 Purple Parabolas, for a total of $233 + 377 = 610$ plants in Leilani's garden. Hopefully she has a big garden!



EXTENSION:

This problem was inspired by a past [Beaver Computing Challenge \(BCC\)](#) problem.

The number of a particular flower type in a specific year is dependent on the number of flowers of each of the types from the previous year. This is an example of a *recursion*.

A famous example of a recursion is known as the *Fibonacci Sequence*. The first two numbers (or *terms*) in the sequence of numbers are defined. They are both 1. Each remaining term in the sequence is equal to the sum of the two previous terms.

So, the third term is equal to the sum of the first and second terms, and is therefore $1 + 1 = 2$.

The fourth term is equal to the sum of the second and third terms, and is therefore $1 + 2 = 3$.

The fifth term is equal to the sum of the third and fourth terms, and is therefore $2 + 3 = 5$.

We can continue generating more terms in the sequence in this manner.

The first 15 Fibonacci numbers are

1, 1, 2, 3, 5, 8, 13, 21, 34, 55, 89, 144, 233, 377, and 610.

In our problem, the number of Purple Parabolas in a given year equals the sum of the number of Blue Starpoints and Purple Parabolas in the previous year. If we had started with only 1 Blue Starpoint and 0 Purple Parabolas, the number of Purple Parabolas after each cycle would match the terms in the Fibonacci sequence. Try it out!



Problème de la semaine

Problème C

Collations et jeux de société

Pavak, Rachit et Sana sont arrivés à une fête à trois moments différents. Ils ont chacun apporté une de leurs collations préférées à partager avec les deux autres (l'un d'eux a apporté des bretzels, un autre des biscuits et un autre de la réglisse). De plus, ils ont chacun apporté leur jeu préféré (l'un d'eux a apporté un jeu d'osselets, un autre des dominos et un autre un jeu de cartes).

Voici quelques autres faits:

1. La personne arrivée en premier n'a pas apporté de biscuits.
2. Pavak était le deuxième à arriver et a apporté un jeu de cartes.
3. Rachit est arrivé avant Sana.
4. La personne qui a apporté des biscuits a également apporté le jeu d'osselets.
5. La personne qui a apporté des bretzels n'a pas apporté les dominos.

Détermine l'ordre dans lequel ils sont arrivés, ainsi que la collation et le jeu que chacun d'eux a apporté.

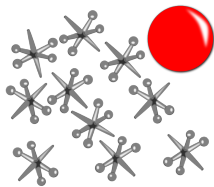



Problem of the Week

Problem C and Solution

Party Games and Snacks

Problem

Pavak, Rachit, and Sana arrived at a party at three different times. They each brought one of their favourite snacks to share with the other two (one brought pretzels; one brought cookies; one brought licorice), and their favourite game (one brought jacks; one brought dominoes; one brought cards).

We know a few other facts:

1. The first to arrive did not bring cookies.
2. Pavak arrived second and brought cards.
3. Rachit arrived before Sana.
4. The person who brought cookies also brought jacks.
5. The person who brought pretzels did not bring dominoes.

Determine the order each person arrived in, what they each brought for a snack, and which game they each brought.

Solution

When solving logic problems, setting up a table to fill in is generally a good way to start.

	Order of Arrival	Snack	Game
Pavak			
Rachit			
Sana			

Some of the given information is often more helpful than other information. For example, in the second statement we learn that Pavak arrived second and brought cards. Now the third statement gives us the fact that Rachit arrived first and Sana arrived third. (This is true since Rachit arrived before Sana and she could not arrive second leaving only the first and third spots left.) We add this information to the table.

	Order of Arrival	Snack	Game
Pavak	2 nd		cards
Rachit	1 st		
Sana	3 rd		



We can combine the first statement and the fourth statement. Rachit did not bring cookies. The person who brought cookies also brought jacks. This cannot be Pavak since he brought cards. Therefore, Sana brought cookies and jacks. Since there is only one game unaccounted for, Rachit must have brought the dominoes. We add this information to our table.

	Order of Arrival	Snack	Game
Pavak	2 nd		cards
Rachit	1 st		dominoes
Sana	3 rd	cookies	jacks

We can now use the fifth statement to conclude that Pavak brought pretzels, since the person bringing pretzels did not bring dominoes and Pavak is the only one without a snack accounted for other than Rachit (who brought the dominoes). We add this information to our table.

	Order of Arrival	Snack	Game
Pavak	2 nd	pretzels	cards
Rachit	1 st		dominoes
Sana	3 rd	cookies	jacks

The only snack unaccounted for is the licorice and Rachit is the only person whose snack is unknown. Therefore, Rachit brought licorice and our table can be completed.

	Order of Arrival	Snack	Game
Pavak	2 nd	pretzels	cards
Rachit	1 st	licorice	dominoes
Sana	3 rd	cookies	jacks

The information is summarized in the table, but will be stated below for completeness.

- Rachit arrived first and brought licorice and dominoes.
- Pavak arrived second and brought pretzels and cards.
- Sana arrived third and brought cookies and jacks.



Problème de la semaine

Problème C

Mes deux cents

Au Canada, les cents sont des pièces de 1 cent qui ont été utilisées jusqu'en 2012. Antonio et Bjorn jouent à un jeu en utilisant deux cents et un plateau de jeu composé d'une rangée de 6 cases. Pour commencer le jeu, les cents sont placés dans les deux cases les plus à gauche, comme dans la figure ci-dessous.



Les règles du jeu sont les suivantes:

- Quand c'est le tour d'un joueur, celui-ci doit déplacer un cent d'une ou de plusieurs cases vers la droite.
- Le cent ne peut pas sauter un autre cent ou atterrir sur une case occupée par un autre cent.
- Le jeu se termine lorsque les cents sont dans les deux cases les plus à droite. Le dernier joueur à avoir déplacé un cent gagne la partie.

Bjorn sait que s'il joue en deuxième, il peut toujours gagner le jeu, quel que soit l'endroit où Antonio déplace les cents lorsque c'est son tour. Décris la stratégie gagnante de Bjorn.



Problem of the Week

Problem C and Solution

Just My Two Cents

Problem

In Canada, pennies are 1 cent coins that were used up until 2012. Antonio and Bjorn are playing a game using two pennies and a game board consisting of a row of 6 squares. To start the game, the pennies are placed in the two leftmost squares, as shown.

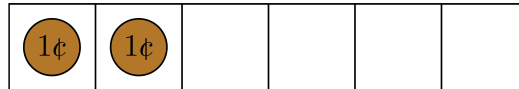

The rules of the game are as follows:

- On a player's turn, the player must move one penny one or more squares to the right.
- The penny may not pass over any other penny or land on a square that is occupied by another penny.
- The game ends when the pennies are in the two rightmost squares. The last player to move a penny wins the game.

Bjorn knows that if he goes second he can always win the game, regardless of where Antonio moves the pennies on his turns. Describe Bjorn's winning strategy.

Solution

First, consider playing the game with just four squares. We will number the squares from 1 to 4, starting on the left. The two pennies would start in squares 1 and 2.

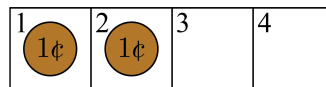

Player 1 has two options for their first turn. They can move the penny in square 2 to either square 4 or square 3.

- *Option 1:* Player 1 moves the penny in square 2 to square 4. Then the pennies would be in squares 1 and 4.

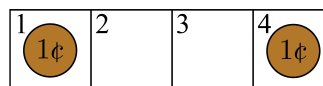

If Player 2 moves the penny in square 1 to square 3, then they would win the game because the pennies would be in squares 3 and 4.

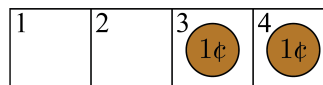



- *Option 2:* Player 1 moves the penny in square 2 to square 3. Then the pennies would be in squares 1 and 3.

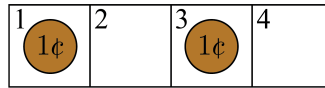

Then Player 2 has two options for their turn. They can either move the penny in square 3 or move the penny in square 1. However, if Player 2 wants to win the game, they should not move the penny in square 3 to square 4. If they do, then the pennies would be in squares 1 and 4, and then Player 1 could move the penny in square 1 to square 3 and win the game. So, Player 2 should move the penny in square 1 to square 2. Then the pennies would be in squares 2 and 3.

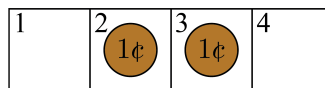

Player 1 would be forced to move the penny in square 3 to square 4. Then the pennies would be in squares 2 and 4.

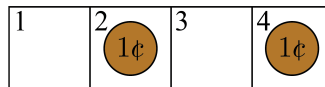

Player 2 would then move the penny in square 2 to square 3, and win the game because the pennies would be in squares 3 and 4.

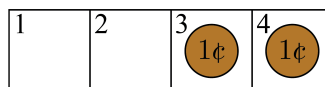

In the game with just two pennies and four squares, Player 2 is always able to win, regardless of what Player 1 does on their turn. If you look closely, you will see that the winning strategy for Player 2 is to copy whatever Player 1 did with the other penny. The two pennies start together. Player 1 must move the rightmost penny, creating a gap between the two pennies. On the following turn, Player 2 can move the other penny in such a way that there is no longer a gap between the two pennies. Doing this ensures that Player 1 must always move the rightmost penny, creating a gap between the pennies which allows Player 2 to always be able to move the leftmost penny and close the gap. Doing this also ensures that Player 2 wins the game.

In fact, the number of squares really does not matter. Bjorn can use this same strategy to win our game with six squares. Whatever Antonio does with the penny on the right, Bjorn “mimics” with the penny on the left. This strategy will guarantee that Bjorn will win the game.



Problème de la semaine

Problème C

Os de chien

Elbashir a écrit un programme informatique pour contrôler le chien Scruffy qui se déplace le long d'une rangée de dix cases, dont certaines contiennent un os, comme dans la figure ci-dessous.

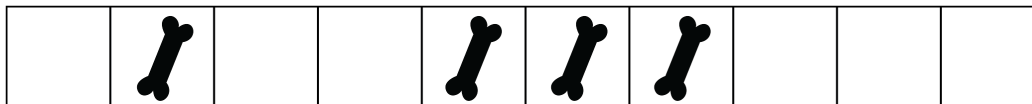

Elbashir a écrit des fonctions qui permettent à Scruffy de se déplacer vers la gauche ou vers la droite d'un nombre donné de cases et de ramasser un os ou de déposer un os. Cependant, il faut faire attention à la manière dont on utilise ces fonctions. Scruffy ne peut tenir qu'un seul os à la fois, il ne peut donc pas ramasser un os s'il en tient déjà un. De même, il ne peut pas déposer un os s'il n'en tient pas un. Toute tentative d'effectuer l'une ou l'autre de ces actions entraînera une erreur et l'arrêt du programme.

Lorsque le programme démarre, Scruffy se trouve dans la case la plus à gauche et ne tient pas d'os.

- (a) Elbashir essaie d'exécuter les instructions informatiques suivantes, mais elles contiennent une erreur et le programme s'arrête. Sur laquelle des lignes d'instructions le programme s'arrête-t-il ? Pourquoi?

Ligne	Instructions
1	RÉPÉTER 2 fois:
2	se déplacer de 4 cases vers la droite
3	ramasser l'os
4	se déplacer de 2 cases vers la gauche
5	déposer l'os
6	terminer RÉPÉTER
7	se déplacer d'une case vers la gauche
8	ramasser l'os
9	se déplacer de 3 cases vers la droite
10	déposer l'os

- (b) Réécris les instructions informatiques de manière que le programme s'exécute correctement et qu'une fois terminé, les os se trouvent dans les quatre cases les plus à droite. Pour relever un défi supplémentaire, essaie de réaliser ce programme en utilisant seulement 10 lignes d'instructions.



Problem of the Week

Problem C and Solution

Dog Bones

Problem

Elbashir wrote a computer program to control Scruffy the dog as he moves along a row of ten squares, some of which contain a bone, as shown.

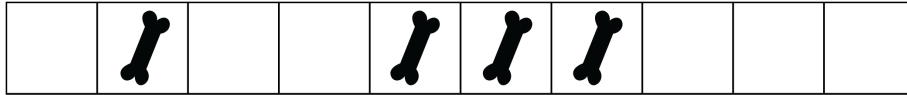

Elbashir wrote functions that allow Scruffy to move left or right a given number of squares, pick up a bone, or put down a bone. However, some care needs to be taken when using the functions. Scruffy can hold only one bone at a time, so cannot pick up a bone if he is already holding one. Similarly, he cannot put down a bone if he isn't holding one. Trying to do either of these actions will result in an error and cause the program to stop.

When the program starts, Scruffy is in the leftmost square and is not holding a bone.

- (a) Elbashir tries to run the following code, but it contains an error so the program stops. On which line of code does the program stop? Why?

Line Number	Code
1	REPEAT 2 times:
2	move 4 squares right
3	pick up bone
4	move 2 squares left
5	put down bone
6	end REPEAT
7	move 1 square left
8	pick up bone
9	move 3 squares right
10	put down bone

- (b) Rewrite the code so that the program runs properly and once it's finished, the bones are in the four rightmost squares. As an extra challenge, see if you can do this using only 10 lines of code.

Solution

- (a) To find the line with the error we will trace through the code. We number the squares from 1 to 10, starting on the left, and mark Scruffy's position with a paw print. The bones are initially in squares 2, 5, 6, and 7, and Scruffy is in square 1.

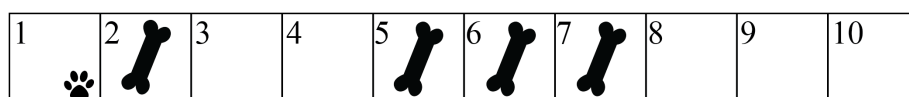



The first line tells Scruffy to move 4 squares right to square 5, which has a bone. He picks up the bone and then moves 2 squares left to square 3, which is empty. He puts down the bone. Thus, after the first time through the repeat block, the bones are in squares 2, 3, 6, and 7, and Scruffy is in square 3.

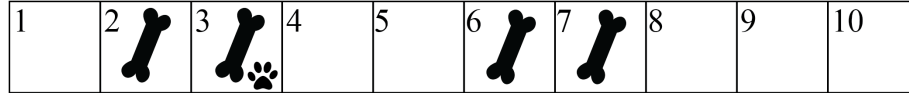

We then go through the repeat block a second time. From square 3, Scruffy moves 4 squares right to square 7, which has a bone. He picks up the bone and moves 2 squares left to square 5, which is empty. He puts down the bone. Thus, after the second time through the repeat block, the bones are in squares 2, 3, 5, and 6, and Scruffy is in square 5.



From square 5, line 7 of the code tells Scruffy to move 1 square left to square 4, which is empty. The next line of code says to pick up a bone, but since square 4 is empty, this results in an error and causes the program to stop. So the program stops on line 8.

- (b) There are many ways to rewrite the code so that the bones are in the four rightmost squares after the program runs. An example is shown to the right.

The bones in squares 2, 5, and 6 need to be moved to squares 8, 9, and 10, in any order. To move each bone it takes 4 lines of code because Scruffy needs to move to a square with a bone, pick up the bone, move to an empty square, and put down the bone. Thus, if each line of code is executed once, then it would take 12 lines of code in total.

```

move 1 square right
pick up bone
move 8 squares right
put down bone
move 5 squares left
pick up bone
move 4 squares right
put down bone
move 3 squares left
pick up bone
move 2 squares right
put down bone
    
```

If we want to move the 3 bones using only 10 lines of code, we will need to make use of a REPEAT block. An example is shown to the right.

```

move 1 square right
pick up bone
move 6 squares right
put down bone
REPEAT 2 times:
    move 3 squares left
    pick up bone
    move 4 squares right
    put down bone
end REPEAT
    
```



Problème de la semaine

Problème C

La randonnée

Il y a cinq personnes dans la famille Hidaka : Shun, Naoki, Kana, Daichi et Mitsuko. Aucun d'entre eux n'a le même âge. La famille marche le long d'un sentier de randonnée en se suivant à la queue leu leu. Tout en marchant, chaque personne compte le nombre de personnes de sa famille qui sont plus âgées qu'elle, devant et derrière elle. Cette information est présentée dans le tableau ci-dessous.

Membre de la famille	Nombre de personnes plus âgées devant	Nombre de personnes plus âgées derrière
Shun	1	2
Naoki	3	1
Kana	0	0
Daichi	2	0
Mitsuko	1	0

Détermine l'ordre dans lequel les membres de la famille marchent. Puis, place les membres de la famille en ordre du plus vieux au plus jeune.



Ce problème est inspiré d'un problème du [Beaver Computing Challenge \(BCC\)](#).



Problem of the Week

Problem C and Solution

Taking a Hike

Problem

There are five people in the Hidaka family: Shun, Naoki, Kana, Daichi, and Mitsuko. No two people are the same age. The family walks along a hiking trail in a single-file line. As they walk, each person counts the number of people in their family both in front of them and behind them who are older than them. This information is shown in the table.

Family Member	Number of older people in front	Number of older people behind
Shun	1	2
Naoki	3	1
Kana	0	0
Daichi	2	0
Mitsuko	1	0

Determine the order that the family members are walking in. Then list the family members in order from oldest to youngest.

This problem was inspired by a past [Beaver Computing Challenge \(BCC\)](#) problem.

Solution

Since Kana is the only person who has nobody older in front of her, it follows that Kana must be the first in line. Since she also has nobody older behind her, she must also be the oldest. This information is summarized in the tables below.

Position in Line	Name of Person
First	Kana
Second	
Third	
Fourth	
Fifth	

Age Ranking	Name of Person
Oldest	Kana
Second Oldest	
Middle	
Second Youngest	
Youngest	

Since Naoki has three older people in front of him and one older person behind him, he must be fourth in line. Also, since four people are older than him, it follows that Naoki is the youngest. This information is summarized in the tables below.

Position in Line	Name of Person
First	Kana
Second	
Third	
Fourth	Naoki
Fifth	

Age Ranking	Name of Person
Oldest	Kana
Second Oldest	
Middle	
Second Youngest	
Youngest	Naoki



Since Shun has two older people behind him, he must be second in line, because Naoki is younger than him. In fact, Naoki is the only person who is younger than him, so it follows that Shun is second youngest. This information is summarized in the tables below.

Position in Line	Name of Person
First	Kana
Second	Shun
Third	
Fourth	Naoki
Fifth	

Age Ranking	Name of Person
Oldest	Kana
Second Oldest	
Middle	
Second Youngest	Shun
Youngest	Naoki

We are left with Daichi and Mitsuko. Since Daichi has two older people in front of him, but Mitsuko has only one older person in front of her, it follows that Mitsuko must be older than Daichi and must also be in front of Daichi. Thus, Mitsuko is third in line and is second oldest, and Daichi is fifth in line and is in the middle of the age ranking. This information allows us to complete the tables as shown below.

Position in Line	Name of Person
First	Kana
Second	Shun
Third	Mitsuko
Fourth	Naoki
Fifth	Daichi

Age Ranking	Name of Person
Oldest	Kana
Second Oldest	Mitsuko
Middle	Daichi
Second Youngest	Shun
Youngest	Naoki

Note that the age rankings could also have been determined by adding the two rightmost columns in the original table. This would give us the number of people older than each person. From that we could write the family members in order from oldest to youngest.